



# energy efficient ventilation

Meet our HERU IQ® family. Our range of high performing Air Handling Units with energy recovery includes products for all kinds of homes, schools, offices and small size public & commercial facilities. A healthy indoor environment with maximum comfort and minimum energy consumption is achieved by controlled ventilation with energy recovery.

HERU IQ® supplies the building with fresh tempered, filtered and clean air. HERU IQ® recovers up to 86% of the energy from the exhausted air.

Through its award-winning design, the Air Handling Units meets the requirements of high efficiency, low power consumption, quiet operation and high reliability.

Quality has always been an essential part of H. Östberg AB. The company is certified according to the quality and environment standards ISO 9001 and ISO 14001. These strict demands guarantee efficient and rational production of high standard products.

All our Air Handling Units are tested before delivery, which secure the high quality of the production. The indoor air quality directly affects the way we feel, not only physically but also spiritually. Therefore, use Östberg quality products to achieve a fresh and healthy indoor climate with energy efficient ventilation.



Air Handling Units for residential, commercial and public environments



Compact Combi Unit for Heating and Ventilation of private Villas

© H. Östberg AB, Avesta, Sweden, 2018. All rights reserved.

No parts of this catalogue may be reproduced or transmitted in any form or by any mean, without the written permission of H. Östberg AB. H. Östberg AB reserves the right to make changes without further notice, and for any printing errors.







Östberg supplies energy efficient and high performance ventilation products for a fresh and healthy indoor climate, wherever people live, work or play. Founded in Sweden in the early 1980s, Östberg has grown into a leading global supplier of duct fans and energy efficient air treatment units – with product sales in over 75 countries.

# healthy indoor climate

## FLEXIBLE AND CUSTOMISED

Consistent customer focus and great flexibility play key roles in Östberg's business concept. We consider it of particular importance to create a truly world-class indoor environment with the lowest possible energy consumption and sound levels. Our comprehensive product range features units that can handle airflows from 50 litres to 1.2 cubic metres per second.

All our products are CE-labelled for EU, EFTA and EEA markets, and we place great emphasis on making them simple to install and to use.

## RESEARCH AND PRODUCT DEVELOPMENT

To maintain and grow the position as a leading technical supplier of high end quality products, Östberg continuously invests heavily in innovation and product development. Our ideas for product development arise from collaborations with our customers, innovations by our technical experts and from our desire to create even better indoor climates. In our efforts to continuously develop our products, we perform numerous tests and measurements – all in order to meet our customers needs and provide healthier air using energy efficient fans and ventilation products at competitive prices.

## QUALITY ASSURED PRODUCTS

Östberg upholds the highest standards for production, with secure quality controls monitoring each product throughout the entire manufacturing process. The company is certified according to the quality and environment standards ISO 9001 and ISO 14001. Östberg is headquartered in Sweden with branches in many countries all over the world.

By choosing an Östberg product you invest in long-lasting quality products powered by innovation.



- H. Östberg AB was the first in Europe to develop small energy recovery units with rotary exchangers at competitive prices for single-family homes and apartments.
- The Swedish Energy Agency announced the HERU®S as the winner of its major energy recovery unit competition
- Many others have also discovered that HERU® offers better energy use and increased comfort at a low investment cost.
- HERU®'s high temperature efficiency also applies at below-freezing temperatures, setting it apart from cross- or counter-current plate heat exchangers, which require defrosting or reduction of supply air through the exchanger so it don't freeze up. Defrosting reduces efficiency by 5-10% according to the Technical Research Institute of Sweden and requires extra energy to heat the supply air that doesn't pass through the exchanger.
- A comparison should also be made here with extract air heat pumps, in which 100% of the supply air must be heated by the building's heating system.
- HERU® is ideal for e.g. passive houses, where the goal is to have the absolute minimum installed power, especially for heating.

## CLEAN INDOOR AIR AND OPTIMAL COMFORT

**Controlled ventilation with energy recovery gives you a healthy indoor climate with the highest comfort and the lowest energy consumption.**

Many apartments and small houses have insufficient ventilation. Poor indoor air leads to allergies and respiratory problems. It saps your energy and impairs your ability to concentrate.

Heating costs are constantly rising. Because of this, many buildings have been sealed in recent decades in order to reduce energy consumption. But the consequences of this are, among other things, moisture and mould.

HERU® supplies your home with filtered, fresh and clean air while utilizing the heat (or cold) in the used extract air. This results in the lowest possible heating costs for you.



# HERU®

## ENERGY RECOVERY UNIT

HERU® is designed for supply and extract air ventilation with energy recovery (FTX).

HERU® has been tested at HLK Stuttgart in accordance with EN 13141-7 and recovers up to 86% of the energy that is otherwise lost in conventional ventilation, such as natural draught or extract air ventilation.

Airflow is generated by two silent radial fans with EC motors. HERU® with EC motors can reduce the fans' energy use by up to 70% in comparison with conventional AC motors. The fans are connected with quick connectors and are very easy to remove for cleaning.

Unique design minimizes all thermal bridges. The sealing properties of HERU® have been tested. External leakage meets class A1. Internal leakage was measured at 2.6% and meets class C3.

HERU® have filters ISO ePM1 as standard ISO 16890, for both exhaust and supply air. Is suitable for installation in apartments, small houses, offices and other premises requiring the highest efficiency, low energy use (SFP), low sound levels, high operating reliability and, of course, clean indoor air.

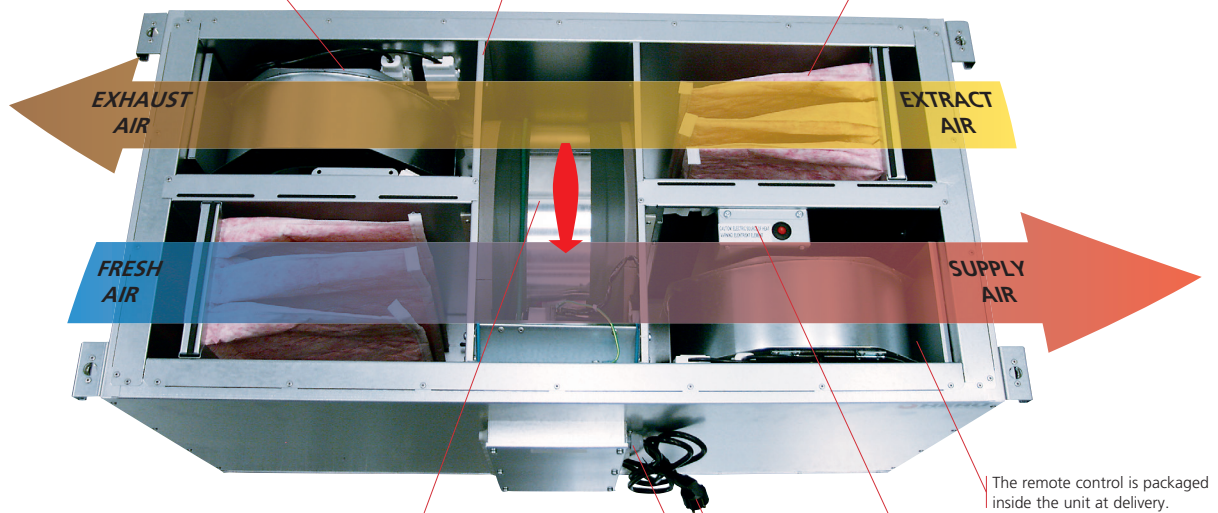

HERU® has a regenerative, non-hygroscopic, aluminium rotating heat exchanger located in the centre of the unit. This exchanger has a very high total annual efficiency rate. This means that the temperature efficiency rate is high – up to 86%. No defrosting or condensation water drainage is needed because no ice forms in the exchanger. Total efficiency (enthalpy) is therefore up to 25% higher than for all types of plate heat exchangers. Another big advantage is that in the summer, HERU® with its rotating heat exchanger provides fully automatic night cooling.

The remote control is packaged inside the unit at delivery.

Available with or without integrated electric heater.

Equipped with wall plug (models up to and including HERU®160 T and HERU®130 S).

HERU® is supplied with the antenna connected.

HERU® available in 4 models: K, T, LP och S.



### HERU®K KITCHEN UNIT WITH INTEGRATED COOKER HOOD

Designed to be placed above the cooker hood. Ventilates the entire home and also effectively captures fumes from the cooker hood. Removes food odours, fumes and steam from the kitchen while you're cooking.

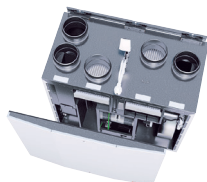

### HERU®T TOP CONNECTED UNIT

The smaller HERU®95–250 T can be placed in warm spaces, such as laundry rooms. The larger HERU®400–1200 T can be placed in both warm and cool spaces. HERU®95–160 T are constructed of white painted galvanized steel sheet. HERU®200–1200 T are constructed of zinc aluminium.

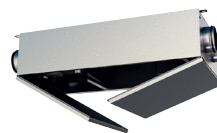

### HERU®LP SIDE CONNECTED UNIT WITH LOW PROFILE

Perfect for cramped or narrow spaces and can be advantageously placed above a false ceiling. Made of double galvanized steel with insulation between.



### HERU®S SIDE CONNECTED UNIT

HERU®100–250 S are constructed of double-layer galvanized steel sheet with 50 mm insulation in between, and comes unpainted. Can be placed in warm or cold areas, such as in the attic. HERU®400–1200 are made from aluminium-zinc-plated steel with 50 mm insulation.

## HERU® CAN BE CONTROLLED IN SEVERAL WAYS

**HERU® 95–250 can be easily controlled using the remote control supplied with the unit.  
For HERU®400–1200, we offer the Siemens Climatix control system.  
All HERU® units are prepared for Modbus communication via RS485.**



FOR EASY HANDLING, HERU®95–250 are remote controlled using the wireless control unit, which has a range of up to 50 metres and works through walls and ceilings.

The remote control is used to set all parameters for the control functions. It also provides information on current status and alarms.

HERU®400-1200 is available with Siemens Climatix for many functions and communication options. The control and regulation system sends prompt alarms if the unit stops and for other unforeseen events.

- We have chosen Modbus communication for HERU® because it is a global standard, easy to implement in its own systems and offers many options for configuration with other systems.
- Modbus offers a number of options for communication. These range from a single computer monitoring one unit, to a complete BMS system monitoring an entire building or several buildings at the same time.

## EASY INSTALLATION AND SERVICE

**HERU® is easy to install and maintain. You can quickly enjoy the benefits of the best possible comfort, highest air quality and lowest possible heating costs.**

### INSTALLATION

Regular spiral ducts are routed from the various rooms: extract air ducts from the kitchen and bathrooms, supply air ducts to the living room and bedrooms.

HERU® 95-250 T can be placed in warm spaces, such as laundry rooms, storage rooms or utility rooms. On some HERU® T models, the cooker hood has a separate extract air connection at the top of the unit. This air does not pass through the heat exchanger, but instead goes via the fan directly into the exhaust air duct.

Other HERU® models can be placed in warm or cool areas.

### LONG SERVICE LIFE WITH WARRANTY

HERU® was developed and produced in Sweden for nordic conditions. We have many years of experience manufacturing small energy recovery units with rotary heat exchangers. All components in the unit are of the highest possible quality, which paves the way for many years of trouble-free operation.

HERU® is virtually maintenance-free. All you need to do is change the filter once or twice a year, depending on the location of the building. If a filter of the stipulated quality is used and no cooker hood is connected, the fans and heat exchanger never need to be cleaned.

All HERU® models should have continuous operation, provided that accessories/equipment (such as filters) from the H. Östberg AB range are used for warranty validity.

### FILTER CHANGE

HERU is equipped with energy-efficient filters classified according to ISO 16890 as standard. Equal to both supply- and exhaust air.

The filter should be changed when the alarm is triggered.

### SERVICE AND CLEANING

HERU® airflow is generated by two silent radial fans with the absolute highest efficiency and quality on the market. The fans are connected with quick connectors and are very easy to remove. The heat exchanger can also be removed.

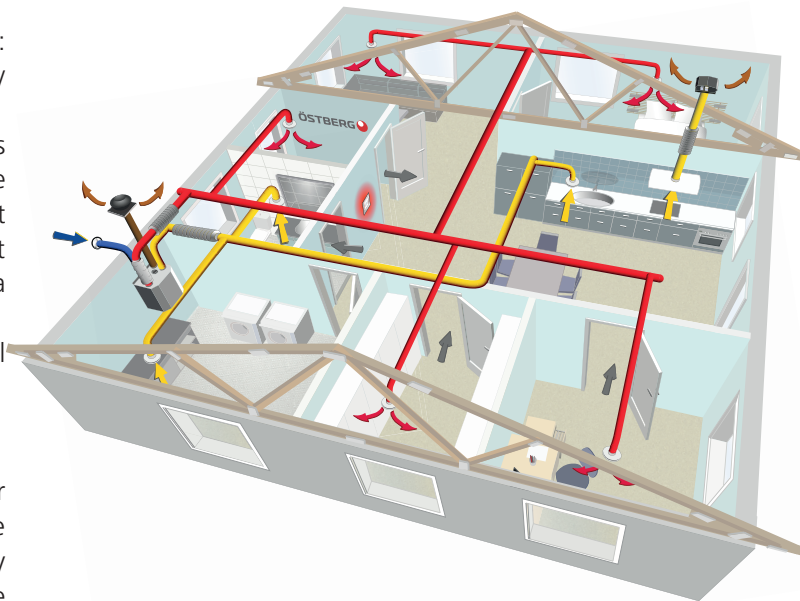

- Place the remote control somewhere you easily can check the unit's current status.
- HERU® supplies your house with filtered, fresh and clean air while recovering the heat (or cold) in the used extract air.
- Temperate fresh air is distributed throughout your home where it is most needed – in the bedrooms and living room – without the cold draughts that often occur with conventional ventilation, including extract air heat pumps. At the same time, the used air is extracted from the kitchen, bathroom and other high-moisture areas.







## ENERGY RECOVERY UNITS

<b>HERU®K</b> .....	<b>12</b>
Kitchen unit with energy recovery for installation above the kitchen stove. HERU®K is available with EC motors. Airflows up to 325 m <sup>3</sup> /h (0.9 m <sup>3</sup> /s).	
<b>HERU®T</b> .....	<b>14</b>
Unit with energy recovery and top connections. HERU®T is available with EC motors. Airflows up to 4300 m <sup>3</sup> /h (1.2 m <sup>3</sup> /s).	
<b>HERU®LP</b> .....	<b>32</b>
Low profile unit with energy recovery and side connections. HERU®LP is available with EC motors. Airflows up to 375 m <sup>3</sup> /h (0.10 m <sup>3</sup> /s).	
<b>HERU®S</b> .....	<b>36</b>
Unit with energy recovery and side connections. HERU®S is available with EC motors. Airflows up to 4300 m <sup>3</sup> /h (1.2 m <sup>3</sup> /s).	

## SUPPLY AIR UNITS

<b>SAU</b> .....	<b>54</b>
SAU supply air unit is designed to provide a comfortable indoor climate with controlled heating and clean, filtered air. SAU is available with AC and EC motors. Airflows up to 1000 m <sup>3</sup> /h (0.28 m <sup>3</sup> /s).	

## ACCESSORIES

<b>HERU® ACCESSORIES</b>	
FILTER.....	74
FEET, NOVIBRA MATS, FLOOR STAND .....	75
CEILING MOUNTING PLATE .....	75
COVER STRIP, FRONT COVER .....	75
OUTSIDE WALL HOOD.....	76
CONTROL KIT .....	77
CONTROL SYSTEM SIEMENS CLIMATIX.....	77
HEATERS .....	78
COOLING COILS.....	78
RELAY PUMP CONTROL.....	78
PRESSURE SENSOR KIT .....	79
DAMPERS.....	79
FLOW METERS.....	79
FILTER MONITORING.....	79
SHUNT.....	79
WATER TRAP .....	79
<b>SAU ACCESSORIES</b>	
FILTER.....	80
FAN CONTROL UNITS.....	80
CONTROL KIT.....	80
REMOTE CONTROL.....	81
ANTENNA.....	81
CONTROL UNIT.....	81
<b>OTHERS ACCESSORIES</b>	
SENSORS.....	82
EXTENSION CABLE, ANTENNA .....	82
SILENCERS.....	83
MOUNTING CLAMP .....	83
BACK DRAUGHT SHUTTERS .....	83
SAFETY GRILLE .....	83
LOUVRE SHUTTER .....	83

# ENERGY RECOVERY UNIT

## HERU®70 K EC

- Energy recovery unit designed mainly for installation above the kitchen stove.
- The HERU®Kitchen is equipped with a built-in cooker hood that will get rid of all unwanted smoke, odors and fumes from your kitchen while you are cooking.
- High efficient odor extractaion form cooker hood.
- Designed for supply and exhaust air ventilation with energy recovery.
- Suitable for installation in homes and other premises where there are stringent requirements on the indoor environment.
- High temperature efficiency 82%, low energy consumption (SFP), low sound level, high operating reliability and provides clean indoor air.
- Unique design minimizes all thermal bridges.
- For easy handling, the unit is remote-controlled using the wireless control unit for operation and monitoring.
- Comes prepared for Modbus communication via RS485 (accessory needed).

- Airflow is generated by two silent radial fans with EC motors and impellers with forward curved blades.
- The fans are connected with quick connectors and are very easy to remove for cleaning.
- A regenerative, non-hygroscopic, aluminum rotating heat exchanger located in the center of the unit. The heat exchanger can also be removed for cleaning.
- Comes with incinerable panel filters ISO ePM1 50% as standard, for both exhaust and supply air. The filter is very easy to change.
- The cooker hood comes equipped with a dishwasher safe grease filter.
- Integrated controls for heating/cooling.
- Equipped with integrated electric heater.
- The unit is constructed from double-layer galvanized steel sheet with insulation in between.
- For placement in warm areas.
- All HERU®Kitchen units are equipped with a wall plug.

### ACCESSORIES

- Filterkit ISO ePM1 50%
- Cover strip
- Front cover
- Outside wall hood 160
- Remote Control with Modbus
- Pressure Sensor Kit
- Damper motor
- Carbon dioxide sensor CO2
- Humidity sensor RH
- Room sensor
- Extension cable to antenna
- Silencer LDC 125



### DIMENSION (mm)

#### RIGHT-HAND DESIGN WITH BUILT-IN COOKER HOOD

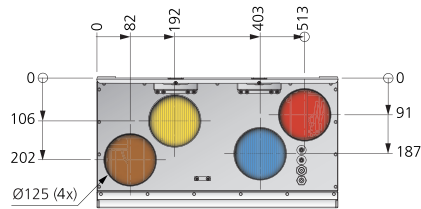
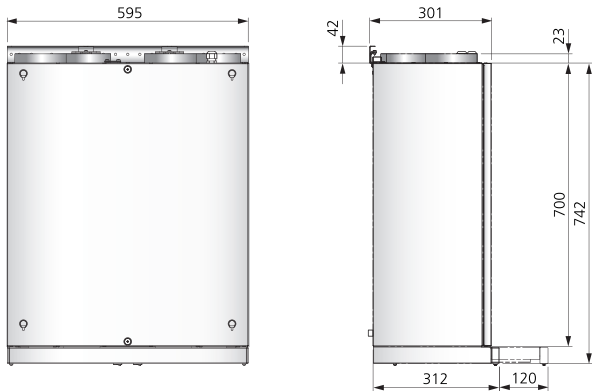

#### LEFT-HAND DESIGN WITH BUILT-IN COOKER HOOD

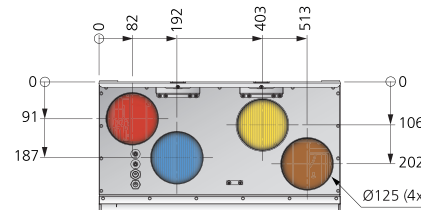
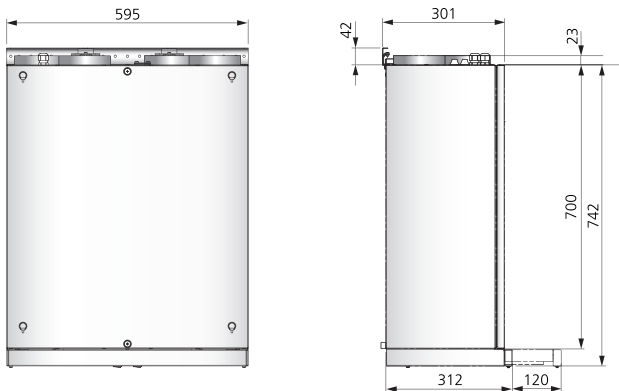

### CONNECTIONS

- Supply air
- Extract air
- Exhaust air
- Fresh air



Type	Art.no.
HERU®70 K EC ARW	8010748
HERU®70 K EC ALW	8010749

# ENERGY RECOVERY UNIT

## HERU<sup>®</sup>70 K EC



### TECHNICAL DATA

HERU <sup>®</sup> 70 K EC	
Voltage	230 V
Frequency	50 Hz
Phase	1 ~
Current, 2 fans	1.81 A
Current, heater	3.26 A
Total current	5.20 A
Power, 2 fans	227 W
Power, heater	750 W
Total power	1000 W
Speed	2980 rpm
Enclosure class	41 IP
Sound pressure level at 3 m	45 dB LpA
Weight	48 kg
Wiring diagram	4040203

### SUPPLY:

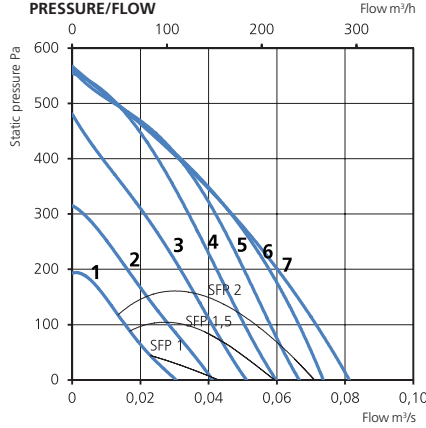

### EXTRACT:

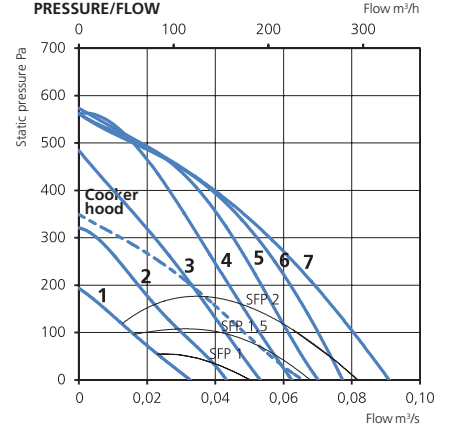

### SOUND DATA (dB)

	Total (L <sub>wa</sub> )	63Hz	125Hz	250Hz	500Hz	1KHz	2KHz	4KHz	8KHz
<b>10V / 68 l/s</b>									
Surrounding	52	36	44	48	43	38	42	39	34
Cooker hood	66	39	47	56	59	59	61	57	53
Supply air	75	59	64	66	69	68	68	65	62
Extract air	66	58	61	62	59	52	49	40	31
<b>6V / 64 l/s</b>									
Surrounding	50	34	43	47	41	37	41	38	32
Cooker hood	62	37	45	52	55	56	56	52	47
Supply air	74	58	62	66	68	67	67	64	60
Extract air	66	57	61	62	59	52	49	40	31
<b>5V / 58 l/s</b>									
Surrounding	49	32	43	45	39	36	39	36	31
Cooker hood	60	35	44	50	52	54	54	50	44
Supply air	72	57	60	64	66	66	65	62	57
Extract air	65	57	58	61	57	50	47	38	29
<b>4V / 52 l/s</b>									
Surrounding	47	30	42	42	37	34	37	34	29
Cooker hood	57	34	43	47	50	52	51	47	40
Supply air	70	55	58	62	64	64	63	59	53
Extract air	63	57	55	58	54	48	45	36	26
<b>3V / 45 l/s</b>									
Surrounding	45	27	41	40	34	32	35	31	28
Cooker hood	55	31	41	44	47	50	48	43	36
Supply air	67	53	56	59	60	61	60	56	49
Extract air	61	57	52	55	50	45	41	32	23
<b>2V / 36 l/s</b>									
Surrounding	42	24	40	35	31	29	31	28	28
Cooker hood	51	28	40	40	44	46	44	38	30
Supply air	63	49	52	55	57	58	55	50	41
Extract air	56	52	48	51	45	41	37	27	17
<b>1V / 26 l/s</b>									
Surrounding	41	21	39	31	27	27	27	26	28
Cooker hood	46	24	37	35	39	41	38	32	28
Supply air	58	44	49	51	52	53	50	43	32
Extract air	51	47	43	45	40	36	32	21	10

### POWER, FANS/FLOW

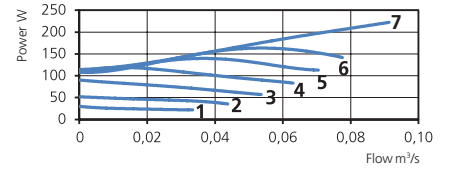

### TEMPERATURE EFFICIENCY

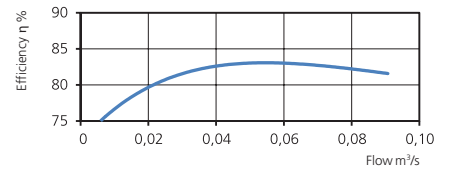

Power and SFP apply for both of the fans together.

### CONTROL VOLTAGE

1	2	3	4	5	6	7
1V	2V	3V	4V	5V	6V	10V

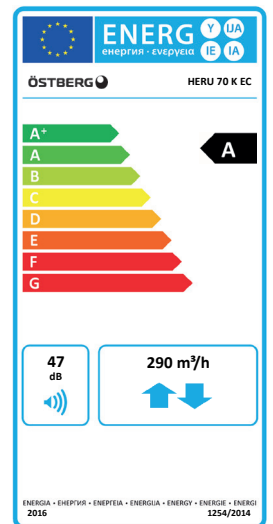

# ENERGY RECOVERY UNIT

## HERU®95 T EC

- Wall-mounted model with top connection.
- Designed for supply and exhaust air ventilation with energy recovery.
- Suitable for installation in apartments, small houses, offices and other premises where there are stringent requirements on the indoor environment.
- High temperature efficiency 86%, low energy consumption (SFP), low sound level, high operating reliability and provides clean indoor air.
- Unique design minimizes all thermal bridges.
- For easy handling, the unit is remote-controlled using the wireless control unit for operation and monitoring.
- Comes equipped for Modbus communication via RS485.
- Airflow is generated by two silent radial fans with EC motors.

- The fans are connected with quick connectors and are very easy to remove for cleaning.
- A regenerative, non-hygroscopic, aluminum rotating heat exchanger located in the center of the unit. The heat exchanger can also be removed for cleaning.
- Incinerable panel filter ISO ePM1 50% as standard, for both exhaust and supply air. The filter is very easy to change.
- Integrated controls for heating/cooling.
- Integrated electric heater.
- The unit is constructed of galvanized steel sheet, partially painted white, and insulated.
- For placement in warm areas, such as laundry, storage or utility rooms.
- Left-hand design.
- Equipped with wall plug.

### ACCESSORIES

- Filterkit ISO ePM1 50%
- Outside wall hood 160
- Remote Control with Modbus
- Heater Kit Water
- Relay pump control
- Damper motor
- Carbon dioxide sensor CO2
- Humidity sensor RH
- Room sensor
- Duct sensor
- Freeze protection sensor
- Extension cable to antenna
- Silencer LDC 125



### DIMENSIONS (mm)

#### LEFT-HAND DESIGN WITH COOKER HOOD CONNECTION

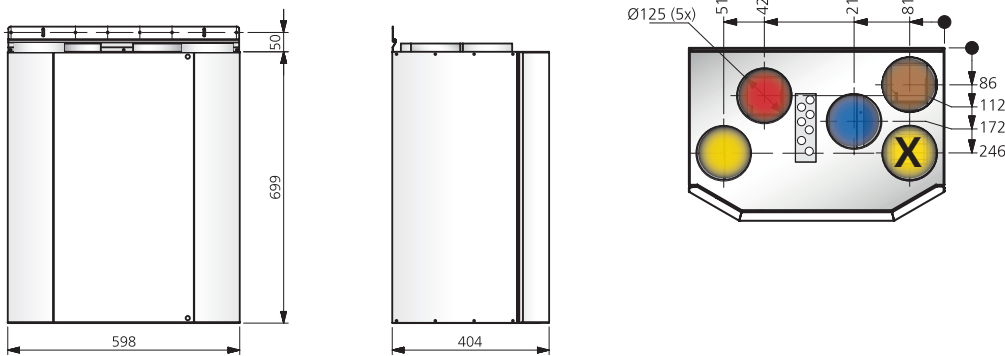

### CONNECTIONS

- Supply air
- Extract air
- Exhaust air
- Fresh air
- Cooker hood

Top connection

Capacity

EC = Fans with low-energy motors

HERU®95T EC ALC

C = With cooker hood connection

Integrated electric heater with:  
A = Full power

L = Left-hand design

Type	Art.no.
HERU®95 T EC ALC	8010735



# ENERGY RECOVERY UNIT

## HERU®95 T EC



### TECHNICAL DATA

HERU®95 T EC	ALC
<b>Voltage</b>	230 V
<b>Frequency</b>	50 Hz
<b>Phase</b>	1 ~
<b>Current, 2 fans</b>	1.98 A
<b>Current, electric heater</b>	5.22 A
<b>Total current</b>	7.30 A
<b>Power, 2 fans</b>	245 W
<b>Power, electric heater</b>	1200 W
<b>Total power</b>	1470 W
<b>Speed</b>	2790 rpm
<b>Enclosure class</b>	41 IP
<b>Sound pressure level, 3 m</b>	45 dB L <sub>PA</sub>
<b>Weight</b>	53 kg
<b>Wiring diagram</b>	404013

### SOUND DATA (dB)

	Total (L <sub>wa</sub> )	63 Hz	125 Hz	250 Hz	500 Hz	1k Hz	2k Hz	4k Hz	8k Hz
<b>10 V / 87 l/s</b>									
Surrounding	52	34	43	50	45	37	34	33	30
Supply air	79	62	64	71	75	70	73	69	67
Extract air	63	54	52	59	56	54	50	44	33
<b>8 V / 80 l/s</b>									
Surrounding	51	35	41	49	43	36	33	32	29
Supply air	78	60	62	70	73	68	70	67	65
Extract air	63	55	52	59	56	53	50	44	33
<b>6 V / 70 l/s</b>									
Surrounding	48	30	39	46	40	33	30	31	29
Supply air	75	57	60	68	70	66	67	64	61
Extract air	60	50	53	56	52	51	48	41	30
<b>5 V / 65 l/s</b>									
Surrounding	47	31	39	45	39	32	29	30	29
Supply air	73	56	59	66	68	65	65	62	58
Extract air	59	46	53	54	51	49	46	39	27
<b>4 V / 56 l/s</b>									
Surrounding	45	30	37	42	37	30	27	31	29
Supply air	70	54	57	64	65	62	61	59	53
Extract air	57	46	50	52	49	47	43	36	24
<b>3 V / 46 l/s</b>									
Surrounding	43	27	36	40	34	29	27	28	29
Supply air	68	52	55	62	63	60	58	55	48
Extract air	54	45	47	50	46	45	40	33	20
<b>2 V / 36 l/s</b>									
Surrounding	40	25	32	37	30	27	24	27	29
Supply air	64	49	52	59	58	56	53	50	40
Extract air	51	42	46	46	41	40	35	27	12

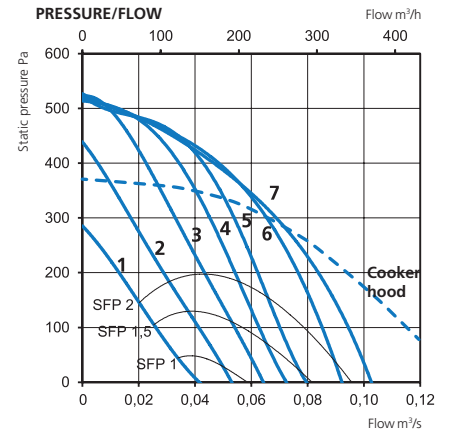

### POWER, FANS/FLOW

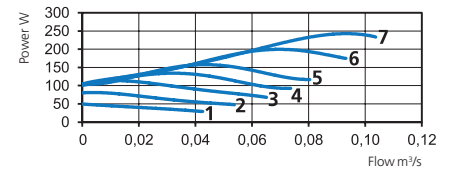

### TEMPERATURE EFFICIENCY

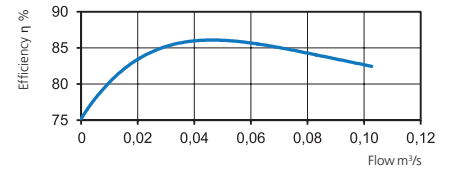

### CONTROL VOLTAGE

1	2	3	4	5	6	7
2V	3V	4V	5V	6V	8V	10V

Pressure/airflow diagrams apply for both supply and extract air. Power and SFP apply for both of the fans together.

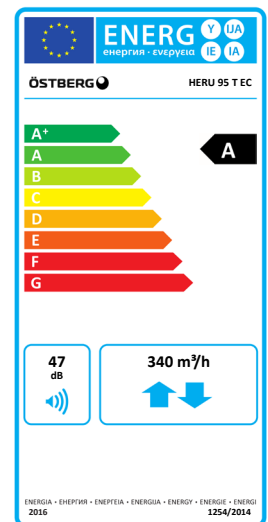

# ENERGY RECOVERY UNIT

## HERU®100 T EC

- Wall-mounted model with top connection.
- Designed for supply and exhaust air ventilation with energy recovery.
- Suitable for installation in apartments, small houses, offices and other premises where there are stringent requirements on the indoor environment.
- High temperature efficiency 86%, low energy consumption (SFP), low sound level, high operating reliability and provides clean indoor air.
- Unique design minimizes all thermal bridges.
- For easy handling, the unit is remote-controlled using the wireless control unit for operation and monitoring.
- Comes prepared for Modbus communication via RS485 (accessory needed).
- Airflow is generated by two silent radial fans with EC motors and impellers with backward curved blades.
- The fans are connected with quick connectors and are very easy to remove for cleaning.

- A regenerative, non-hygroscopic, aluminum rotating heat exchanger located in the center of the unit. The heat exchanger can also be removed for cleaning.
- Incinerable panel filter ISO ePM1 50% as standard, for both exhaust and supply air. The filter is very easy to change.
- Integrated controls for heating/cooling.
- Available with or without integrated electric heater.
- The unit is constructed of galvanized steel sheet, partially painted white, and insulated.
- For placement in warm areas, such as laundry, storage or utility rooms.
- Available in either right-hand or left-hand design. Can be ordered with a connection for a cooker hood. This connection is routed past the rotor to prevent cooking odours from spreading back into the premises.
- Equipped with wall plug.
- Integrated silencer on the supply air and extract air side.

### ACCESSORIES

- Filterkit ISO ePM1 50%
- Ceiling Mounting Plate
- Outside wall hood 160
- Remote Control with Modbus
- Heater Kit Water
- Relay pump control
- Damper motor
- Carbon dioxide sensor CO2
- Humidity sensor RH
- Room sensor
- Duct sensor
- Freeze protection sensor
- Extension cable to antenna
- Silencer LDC 125



### DIMENSIONS (mm)

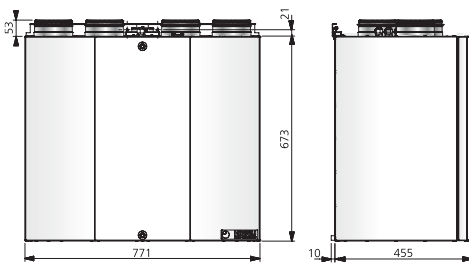

### RIGHT-HAND DESIGN

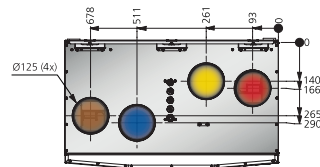

### RIGHT-HAND DESIGN WITH COOKER HOOD CONNECTION

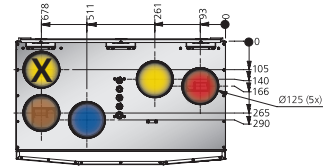

### LEFT-HAND DESIGN

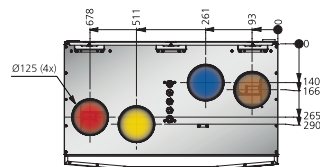

### LEFT-HAND DESIGN WITH COOKER HOOD CONNECTION

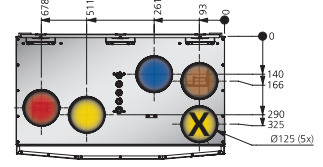

### CONNECTIONS

- Supply air
- Extract air
- Exhaust air
- Fresh air
- ⊗ Cooker hood

Type	Art.no.
HERU®100 T EC AR	8010724
HERU®100 T EC AL	8010725
HERU®100 T AC ARC	8010726
HERU®100 T EC ALC	8010727
HERU®100 T EC BR	8010731
HERU®100 T EC BL	8010728

Top connection

Capacity

# HERU®100T EC ARC

Integrated electric heater with:

- A = Full power
- B = Half power (not stocked)

EC = Fans with low-energy motors

C = With cooker hood connection

- R = Right-hand design
- L = Left-hand design

# ENERGY RECOVERY UNIT

## HERU®100 T EC



### TECHNICAL DATA

HERU®100 T EC	A	B
<b>Voltage</b>	230	230 V
<b>Frequency</b>	50	50 Hz
<b>Phase</b>	1	1 ~
<b>Current, 2 fans</b>	1.65	1.65 A
<b>Current, electric heater</b>	5.22	2.61 A
<b>Total current</b>	7.00	4.40 A
<b>Power, 2 fans</b>	203	203 W
<b>Power, electric heater</b>	1200	600 W
<b>Total power</b>	1430	830 W
<b>Speed</b>	3550	3550 rpm
<b>Enclosure class</b>	41	41 IP
<b>Sound pressure level, 3 m</b>	39	39 dB L <sub>PA</sub>
<b>Weight</b>	65	65 kg
<b>Wiring diagram</b>	4040168	4040168

### SOUND DATA (dB)

	Total (L <sub>WA</sub> )	63 Hz	125 Hz	250 Hz	500 Hz	1k Hz	2k Hz	4k Hz	8k Hz
<b>10 V / 94 l/s</b>									
Surrounding	46	31	41	43	37	32	32	32	29
Supply air	79	62	64	71	75	70	73	69	67
Extract air	60	53	51	53	53	53	43	38	27
<b>9 V / 87 l/s</b>									
Surrounding	46	31	41	41	38	30	31	30	29
Supply air	69	57	61	63	64	54	56	52	47
Extract air	59	52	50	52	52	52	43	37	26
<b>8 V / 76 l/s</b>									
Surrounding	43	28	39	39	31	28	29	29	29
Supply air	66	56	60	62	60	50	53	48	42
Extract air	57	51	49	50	49	50	40	34	24
<b>7 V / 67 l/s</b>									
Surrounding	41	26	37	38	27	27	26	27	28
Supply air	63	54	58	58	56	46	49	44	37
Extract air	55	49	48	47	47	47	37	31	20
<b>6 V / 56 l/s</b>									
Surrounding	39	24	35	35	25	25	24	27	28
Supply air	61	52	56	55	52	42	45	40	32
Extract air	53	48	46	44	44	44	34	27	15
<b>5 V / 48 l/s</b>									
Surrounding	37	23	32	31	26	25	23	26	28
Supply air	57	50	53	50	47	38	40	34	24
Extract air	51	46	43	46	39	40	29	21	10
<b>4 V / 36 l/s</b>									
Surrounding	36	21	31	28	22	24	22	26	28
Supply air	53	48	48	49	43	33	33	25	16
Extract air	47	44	39	39	34	35	23	14	5

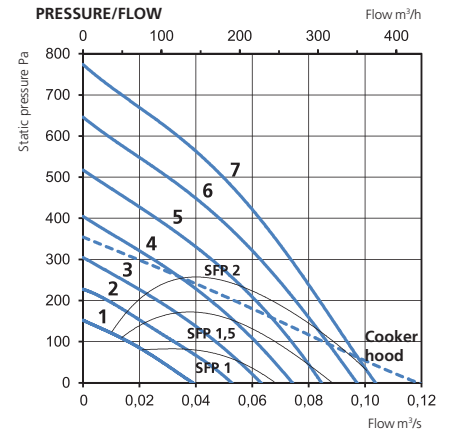

### POWER, FANS/FLOW

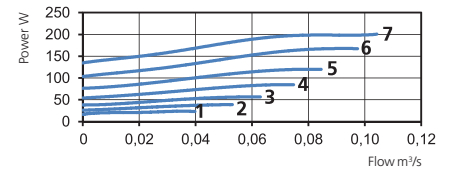

### TEMPERATURE EFFICIENCY

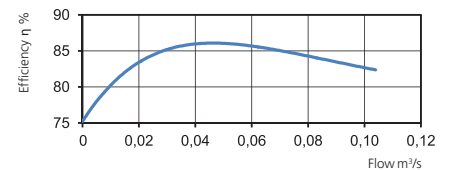

### CONTROL VOLTAGE

1	2	3	4	5	6	7
4V	5V	6V	7V	8V	9V	10V

Pressure/airflow diagrams apply for both supply and extract air. Power and SFP apply for both of the fans together.

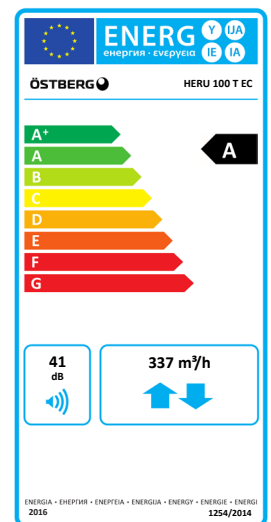

# ENERGY RECOVERY UNIT

## HERU®160 T EC

- Wall-mounted model with top connection.
- Designed for supply and exhaust air ventilation with energy recovery.
- Suitable for installation in apartments, small houses, offices and other premises where there are stringent requirements on the indoor environment.
- High temperature efficiency 86%, low energy consumption (SFP), low sound level, high operating reliability and provides clean indoor air.
- Unique design minimizes all thermal bridges.
- For easy handling, the unit is remote-controlled using the wireless control unit for operation and monitoring.
- Comes prepared for Modbus communication via RS485.
- Airflow is generated by two silent radial fans with EC motors and impellers with backward curved blades.
- The fans are connected with quick connectors and are very easy to remove for cleaning.

- A regenerative, non-hygroscopic, aluminum rotating heat exchanger located in the center of the unit. The heat exchanger can also be removed for cleaning.
- Incinerable panel filter ISO ePM1 50% as standard, for both exhaust and supply air. The filter is very easy to change.
- Integrated controls for heating/cooling.
- Available with or without integrated electric heater.
- The unit is constructed of galvanized steel sheet, partially painted white, and insulated.
- For placement in warm areas, such as laundry, storage or utility rooms.
- Available in either right-hand or left-hand design. Can be ordered with a connection for a cooker hood. This connection is routed past the rotor to prevent cooking odours from spreading back into the premises.
- Equipped with wall plug.
- Integrated silencer on the supply air and extract air side.

### ACCESSORIES

- Filterkit ISO ePM1 50%
- Floor stand
- Outside wall hood 200
- Remote Control with Modbus
- Heater Kit Water
- Relay pump control
- Damper motor
- Carbon dioxide sensor CO2
- Humidity sensor RH
- Room sensor
- Duct sensor
- Freeze protection sensor
- Extension cable to antenna
- Silencer LDC 160



### DIMENSIONS (mm)

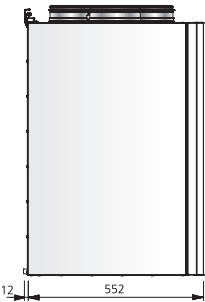
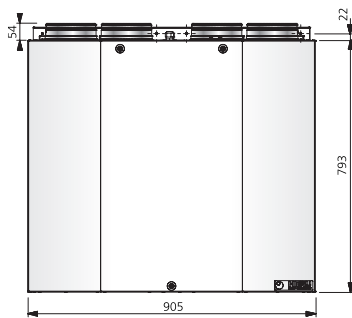

### RIGHT-HAND DESIGN

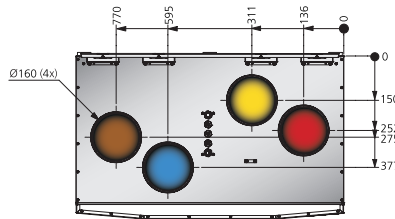

### RIGHT-HAND DESIGN WITH COOKER HOOD CONNECTION

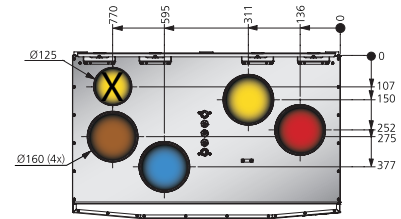

### LEFT-HAND DESIGN

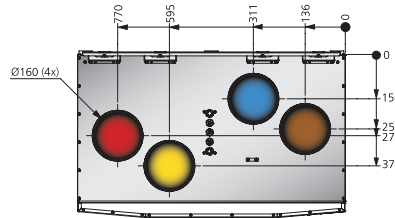

### LEFT-HAND DESIGN WITH COOKER HOOD CONNECTION

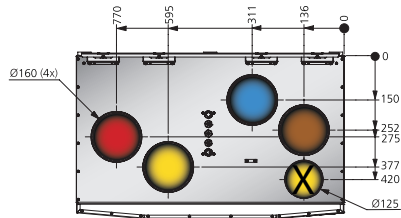

### CONNECTIONS

- Supply air
- Extract air
- Exhaust air
- Fresh air
- Cooker hood

Type	Art.no.
HERU®160 T EC AR	8010370
HERU®160 T EC AL	8010371
HERU®160 T EC ARC	8010372
HERU®160 T EC ALC	8010303
HERU®160 T EC BR	8010380
HERU®160 T EC BL	8010381
HERU®160 T EC CR	8010390
HERU®160 T EC CL	8010391

Top connection

Capacity

EC = Fans with low-energy motors

## HERU®160 T EC ARC

Integrated electric heater with:

- A = Full power
- B = Half power
- C = Without electric heater

C = With cooker hood connection at top  
D = With cooker hood connection at bottom

R = Right-hand design  
L = Left-hand design



# ENERGY RECOVERY UNIT

## HERU®160 T EC



### TECHNICAL DATA

HERU®160 T EC	A	B	C
<b>Voltage</b>	230	230	230 V
<b>Frequency</b>	50	50	50 Hz
<b>Phase</b>	1	1	1 ~
<b>Current, 2 fans</b>	2.53	2.53	2.53 A
<b>Current, electric heater</b>	7.39	3.70	- A
<b>Total current</b>	10.00	6.30	2.63 A
<b>Power, 2 fans</b>	321	321	321 W
<b>Power, electric heater</b>	1700	850	- W
<b>Total power</b>	2050	1200	348 W
<b>Speed</b>	3070	3070	3070 rpm
<b>Enclosure class</b>	41	41	41 IP
<b>Sound pressure level, 3 m</b>	45	45	45 dB L <sub>PA</sub>
<b>Weight</b>	91	91	90 kg
<b>Wiring diagram</b>	4040171	4040171	4040171

### SOUND DATA (dB)

	Total (L <sub>WA</sub> )	63 Hz	125 Hz	250 Hz	500 Hz	1k Hz	2k Hz	4k Hz	8k Hz
<b>10 V / 131 l/s</b>									
Surrounding	52	46	49	49	38	36	34	37	32
Supply air	74	69	68	69	65	58	59	52	45
Extract air	63	54	56	57	58	54	44	37	27
<b>9 V / 129 l/s</b>									
Surrounding	52	46	49	48	38	35	33	34	30
Supply air	74	69	68	69	65	58	59	52	45
Extract air	63	54	57	57	58	54	44	37	27
<b>8 V / 104 l/s</b>									
Surrounding	48	43	45	45	35	32	29	30	29
Supply air	70	62	64	66	61	53	54	47	40
Extract air	59	52	53	51	54	50	39	33	24
<b>7 V / 83 l/s</b>									
Surrounding	46	40	41	44	36	29	26	28	29
Supply air	68	60	60	65	58	49	49	42	34
Extract air	56	50	49	48	50	46	35	28	22
<b>6 V / 67 l/s</b>									
Surrounding	41	37	36	37	27	27	24	27	29
Supply air	63	57	57	59	52	43	43	35	27
Extract air	53	47	45	48	45	41	30	24	21
<b>5 V / 51 l/s</b>									
Surrounding	37	37	32	30	26	26	23	27	29
Supply air	56	52	52	48	46	36	35	26	20
Extract air	46	41	41	35	41	36	25	22	21
<b>4 V / 33 l/s</b>									
Surrounding	35	26	27	29	24	26	23	27	29
Supply air	50	46	46	42	38	28	25	17	18
Extract air	41	36	34	29	36	31	23	21	21

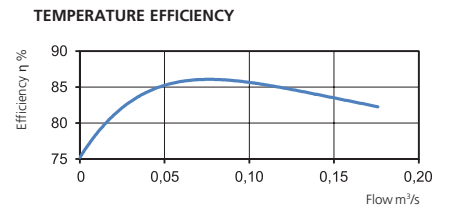
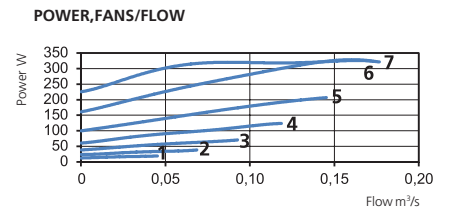
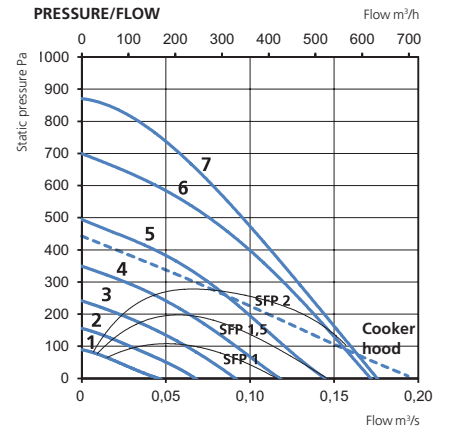

### CONTROL VOLTAGE

1	2	3	4	5	6	7
4V	5V	6V	7V	8V	9V	10V

Pressure/airflow diagrams apply for both supply and extract air. Power and SFP apply for both of the fans together.

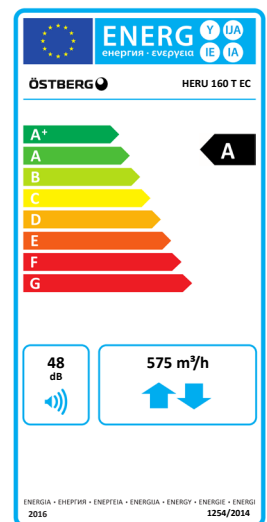

# ENERGY RECOVERY UNIT

## HERU®200 T EC

- Floor model with top connection.
- Designed for supply and exhaust air ventilation with energy recovery.
- Suitable for installation in apartments, small houses, offices and other premises where there are stringent requirements on the indoor environment.
- High temperature efficiency 86%, low energy consumption (SFP), low sound level, high operating reliability and provides clean indoor air.
- Unique design minimizes all thermal bridges.
- For easy handling, the unit is remote-controlled using the wireless control unit for operation and monitoring.
- Comes prepared for Modbus communication via RS485 (accessory needed).
- Airflow is generated by two silent radial fans with EC motors and impellers with backward-curved blades.
- The fans are connected with quick connectors and are very easy to remove for cleaning.

- A regenerative, non-hygroscopic, aluminum rotating heat exchanger located in the center of the unit. The heat exchanger can also be removed for cleaning.
- Incinerable panel filter ISO ePM1 50% as standard, for both exhaust and supply air. The filter is very easy to change.
- Integrated controls for heating/cooling.
- Available with or without integrated electric heater.
- The unit is made from aluminum-zinc-plated steel and insulated.
- For placement in warm areas, such as laundry, storage or utility rooms.
- Available in either right-hand or left-hand design.
- Equipped with wall plug.
- Integrated silencer on the supply air and extract air side.

### ACCESSORIES

- Filterkit ISO ePM1 50%
- Remote Control with Modbus
- Heater Kit Water
- Cooling coil Kit
- Relay pump control
- Damper motor
- Carbon dioxide sensor CO2
- Humidity sensor RH
- Room sensor
- Duct sensor
- Freeze protection sensor
- Extension cable to antenna
- Silencer LDC 250



### DIMENSIONS (mm)

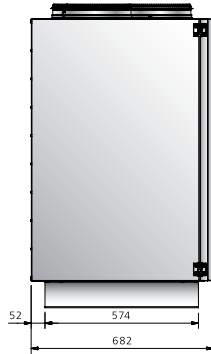
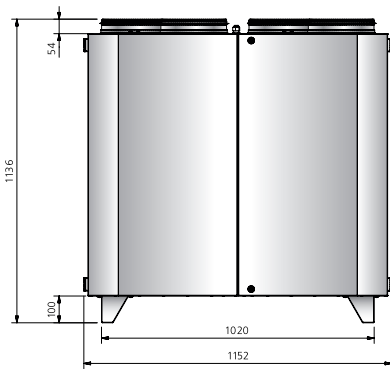

### RIGHT-HAND DESIGN

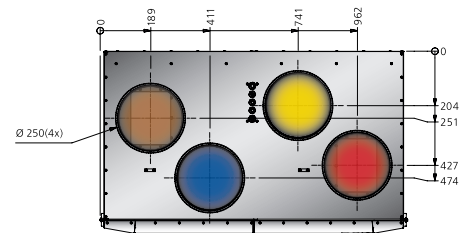

### LEFT-HAND DESIGN

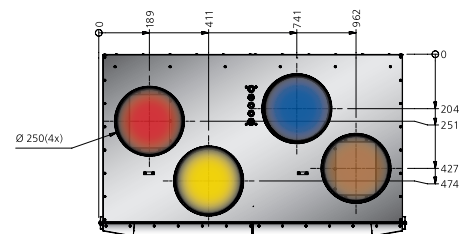

### CONNECTIONS

- Supply air
- Extract air
- Exhaust air
- Fresh air

Top connection

Capacity

EC = Fans with low-energy motors

# HERU®200 T EC AR

Integrated electric heater with:

- A = Full power
- C = Without electric heater

- R = Right-hand design
- L = Left-hand design

Type	Art.no.
HERU®200 T EC AR	8010405
HERU®200 T EC AL	8010407
HERU®200 T EC CR	8010406
HERU®200 T EC CL	8010408



# ENERGY RECOVERY UNIT

## HERU®200 T EC

### TECHNICAL DATA

HERU® 200 T EC	A	C
<b>Voltage</b>	230	230 V
<b>Frequency</b>	50	50 Hz
<b>Phase</b>	1	1 ~
<b>Current, 2 fans</b>	2.56	2.56 A
<b>Current, electric heater</b>	10.00	- A
<b>Total current</b>	12.70	2.66 A
<b>Power, 2 fans</b>	321	321 W
<b>Power, electric heater</b>	2300	- W
<b>Total power</b>	2650	348 W
<b>Speed</b>	2780	2780 rpm
<b>Enclosure class</b>	41	41 IP
<b>Sound pressure level, 3 m</b>	43	43 dB L <sub>PA</sub>
<b>Weight</b>	132	130 kg
<b>Wiring diagram</b>	4040176	4040176

### SOUND DATA (dB)

	Total (L <sub>wa</sub> )	63 Hz	125 Hz	250 Hz	500 Hz	1k Hz	2k Hz	4k Hz	8k Hz
<b>10 V / 175 l/s</b>									
Surrounding	50	45	47	45	41	34	31	29	28
Supply air	70	59	61	66	61	60	58	51	43
Extract air	61	52	53	52	55	53	45	40	26
<b>8 V / 155 l/s</b>									
Surrounding	47	45	43	43	39	33	29	28	28
Supply air	67	56	59	65	57	57	54	46	39
Extract air	58	48	50	53	52	50	42	37	24
<b>7 V / 125 l/s</b>									
Surrounding	45	46	40	41	36	32	27	27	28
Supply air	62	54	55	58	54	52	49	41	33
Extract air	54	47	47	44	48	46	38	32	22
<b>6 V / 101 l/s</b>									
Surrounding	42	44	35	39	34	31	25	26	28
Supply air	62	52	51	60	50	47	44	33	25
Extract air	51	46	44	41	45	42	34	28	22
<b>5 V / 78 l/s</b>									
Surrounding	39	41	34	31	34	31	25	26	28
Supply air	55	48	52	46	42	40	36	24	17
Extract air	48	42	43	35	41	38	31	26	22
<b>4 V / 57 l/s</b>									
Surrounding	39	32	34	29	34	31	24	26	28
Supply air	47	41	44	39	35	32	27	18	15
Extract air	45	35	41	30	40	36	30	26	23

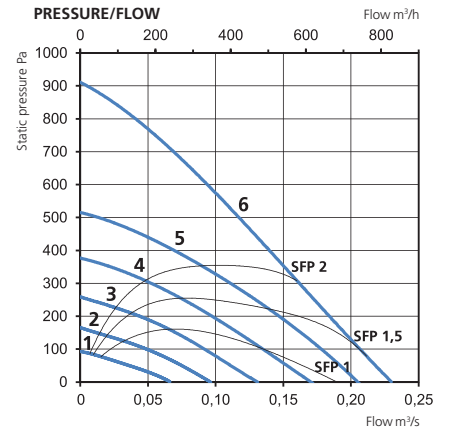

### POWER, FANS/FLOW

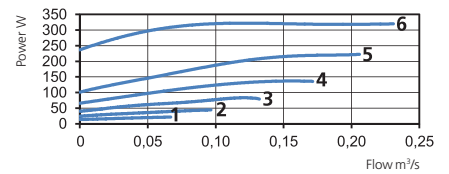

### TEMPERATURE EFFICIENCY

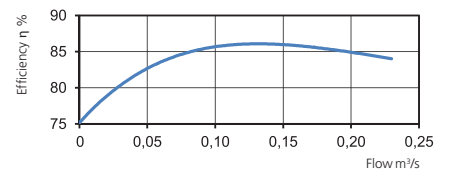

### CONTROL VOLTAGE

1	2	3	4	5	6
4V	5V	6V	7V	8V	10V

Pressure/airflow diagrams apply for both supply and extract air. Power and SFP apply for both of the fans together.

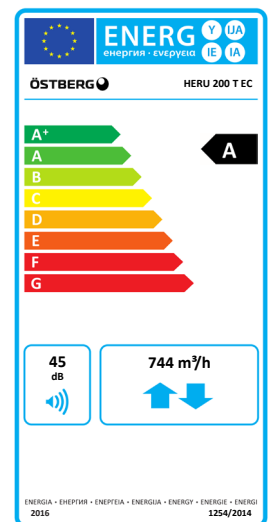



# ENERGY RECOVERY UNIT

## HERU®250 T EC

- Floor model with top connection.
- Designed for supply and exhaust air ventilation with energy recovery.
- Suitable for installation in apartments, small houses, offices and other premises where there are stringent requirements on the indoor environment.
- High temperature efficiency 86%, low energy consumption (SFP), low sound level, high operating reliability and provides clean indoor air.
- Unique design minimizes all thermal bridges.
- For easy handling, the unit is remote-controlled using the wireless control unit for operation and monitoring.
- Comes prepared for Modbus communication via RS485 (accessory needed).
- Airflow is generated by two silent radial fans with EC motors and impellers with backward curved blades.

- The fans are connected with quick connectors and are very easy to remove for cleaning.
- A regenerative, non-hygroscopic, aluminum rotating heat exchanger located in the center of the unit. The heat exchanger can also be removed for cleaning.
- Incinerable panel filter ISO ePM1 50% as standard, for both exhaust and supply air. The filter is very easy to change.
- Integrated controls for heating/cooling.
- Available with or without integrated electric heater.
- The unit is made from aluminum-zinc-plated steel and insulated.
- For placement in warm areas, such as laundry, storage or utility rooms.
- Available in either right-hand or left-hand design.
- Integrated silencer on the supply air and extract air side.

### ACCESSORIES

- Filterkit ISO ePM1 50%
- Remote Control with Modbus
- Heater Kit Water
- Cooling coil Kit
- Relay pump control
- Damper motor
- Carbon dioxide sensor CO2
- Humidity sensor RH
- Room sensor
- Duct sensor
- Freeze protection sensor
- Extension cable to antenna
- Silencer LDC 250



### DIMENSIONS (mm)

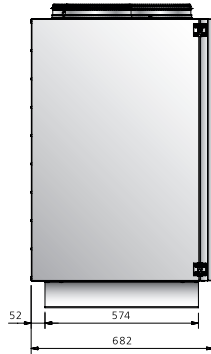
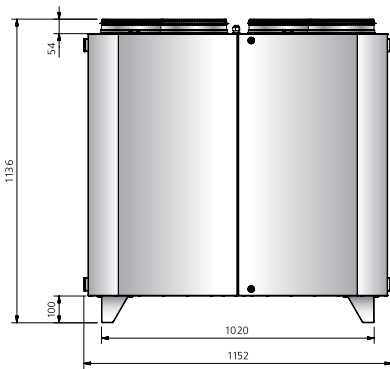

### RIGHT-HAND DESIGN

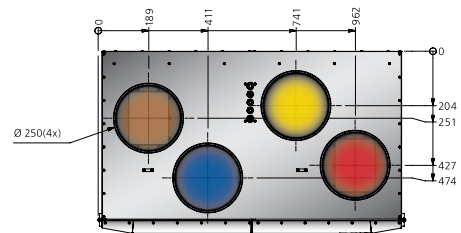

### LEFT-HAND DESIGN

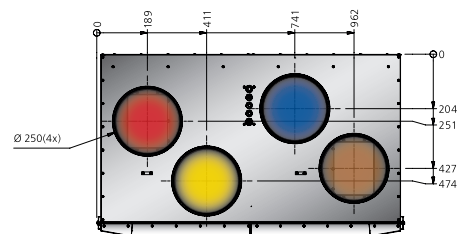

### CONNECTIONS

- Supply air
- Extract air
- Exhaust air
- Fresh air

Top connection

Capacity

EC = Fans with low-energy motors

# HERU®250 T EC 2 AR

Version

Integrated electric heater with:

- A = Full power
- C = Without electric heater

- R = Right-hand design
- L = Left-hand design

Type	Art.no.
HERU®250 T EC 2 AR	8010422
HERU®250 T EC 2 AL	8010424
HERU®250 T EC 2 CR	8010423
HERU®250 T EC 2 CL	8010425

# ENERGY RECOVERY UNIT

## HERU®250 T EC



### TECHNICAL DATA

HERU®250 T EC 2	A	C
<b>Voltage</b>	230	230 V
<b>Frequency</b>	50	50 Hz
<b>Phase</b>	1	1 ~
<b>Current, 2 fans</b>	1.95	1.95 A
<b>Current, electric heater</b>	10.00	- A
<b>Total current</b>	12.10	2.05 A
<b>Power, 2 fans</b>	432	432 W
<b>Power, electric heater</b>	2300	- W
<b>Total power</b>	2760	459 W
<b>Speed</b>	2790	2790 rpm
<b>Enclosure class</b>	41	41 IP
<b>Sound pressure level, 3 m</b>	41	41 dB L <sub>PA</sub>
<b>Weight</b>	146	143 kg
<b>Wiring diagram</b>	4040176	4040176

### SOUND DATA (dB)

	Total (L <sub>wa</sub> )	63 Hz	125 Hz	250 Hz	500 Hz	1k Hz	2k Hz	4k Hz	8k Hz
<b>10 V / 227 l/s</b>									
Surrounding	48	50	43	42	43	34	32	28	27
Supply air	70	57	58	58	63	61	65	58	53
Extract air	61	50	50	49	58	55	51	45	36
<b>9 V / 206 l/s</b>									
Surrounding	46	44	40	39	42	32	29	27	27
Supply air	67	53	55	55	61	57	62	55	49
Extract air	59	48	47	48	56	53	49	43	34
<b>8 V / 178 l/s</b>									
Surrounding	42	39	37	36	38	31	27	26	27
Supply air	64	51	53	52	60	54	58	51	44
Extract air	57	44	45	45	54	50	45	39	29
<b>7 V / 164 l/s</b>									
Surrounding	41	38	35	34	37	30	26	26	27
Supply air	61	49	50	51	56	52	56	48	40
Extract air	55	42	42	43	52	49	43	37	25
<b>6 V / 141 l/s</b>									
Surrounding	39	40	33	32	33	29	25	26	27
Supply air	58	47	49	50	51	48	53	46	36
Extract air	51	40	40	43	47	45	40	34	22
<b>5 V / 126 l/s</b>									
Surrounding	38	34	30	31	32	28	24	25	27
Supply air	55	45	46	50	46	45	49	42	32
Extract air	48	38	38	41	43	42	37	31	18
<b>4 V / 107 l/s</b>									
Surrounding	36	33	28	29	30	28	24	25	27
Supply air	53	43	43	48	43	41	45	38	27
Extract air	45	36	35	38	40	38	34	28	14

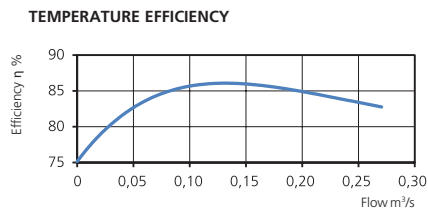
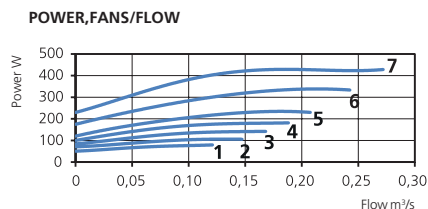
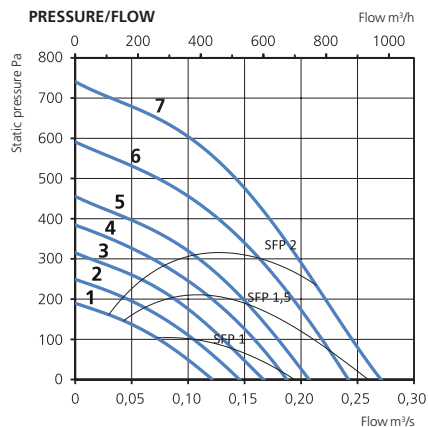

**CONTROL VOLTAGE**

1	2	3	4	5	6	7
4V	5V	6V	7V	8V	9V	10V

Pressure/airflow diagrams apply for both supply and extract air. Power and SFP apply for both of the fans together.

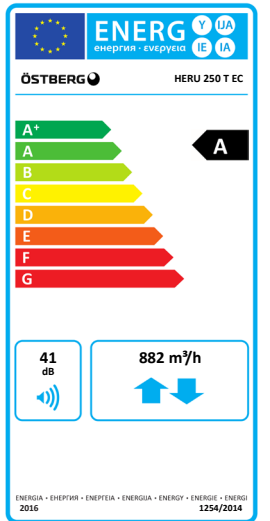

# ENERGY RECOVERY UNIT

## HERU®400 T EC

- Compact unit with top connection.
- Designed for supply and exhaust air ventilation with energy recovery.
- Suitable for installation in homes, offices and other premises where there are stringent requirements on the indoor environment.
- High temperature efficiency 86%, low energy consumption (SFP), low sound level, high operating reliability and provides clean indoor air.
- Unique design minimizes all thermal bridges.
- Can be ordered with integrated Siemens Climatix (CX) control equipment or without control equipment (ET).
- Comes prepared for Modbus communication via RS485 (accessory needed).
- Airflow is generated by two silent anti-vibration plug fans with EC motors and impellers with backward curved blades.

- The fans are connected with quick connectors and are very easy to remove for cleaning.
- Speed controlled rotating aluminum heat exchanger with adjustable hub and purge sector. The rotor can be removed for cleaning.
- Deep pleated filter ISO ePM1 65% as standard, for both exhaust and supply air. The filter is very easy to change.
- Available with integrated electric heater or heating coil.
- The water and electrical connections are positioned to facilitate practical and simple connection.
- The unit is made from aluminum-zinc-plated steel and insulated.
- For placement in both warm and cold environments.
- Available in either right-hand or left-hand design.
- Delivered with adjustable feet and Novibra mats.

### ACCESSORIES

- Filterkit ISO ePM1 65%
- Adjustable feet
- Novibra mat
- Control system
- Cooling coil
- Damper
- Flow meter
- U-pipe filter
- Valve actuator
- Shunt
- Water trap
- Silencer



### DIMENSIONS (mm)

#### RIGHT-HAND DESIGN

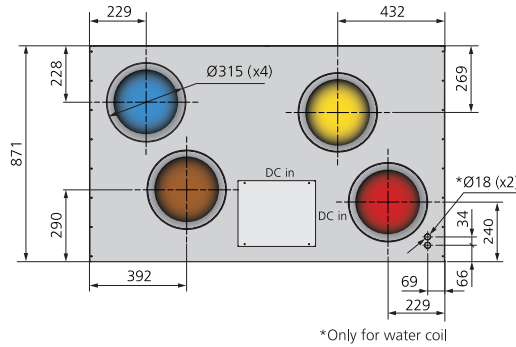
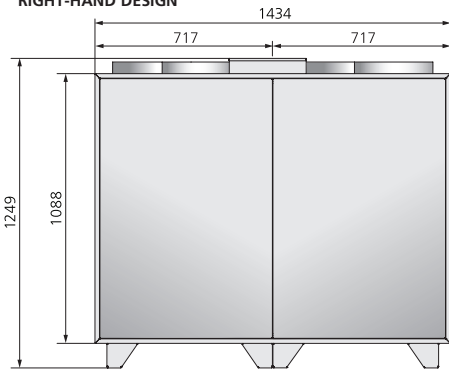

#### LEFT-HAND DESIGN

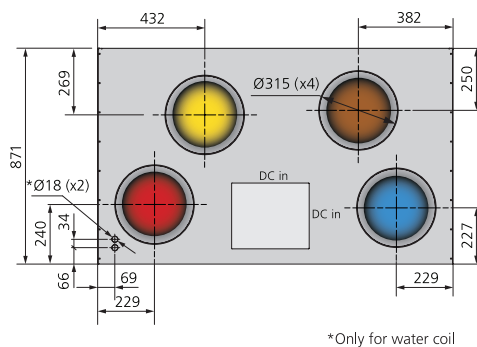
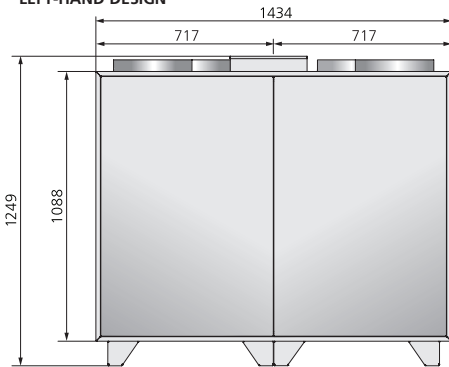

### CONNECTIONS

- Supply air
- Extract air
- Exhaust air
- Fresh air

Top connection

EC = Fans with low-energy motors

Capacity

400V = 3-Phase

HERU®400T EC CX L W-400V

CX = Control system Siemens Climatix  
ET = Without control system, Routed to terminal block

W = Heater kit, water  
E = Electric heater

R = Right-hand design  
L = Left-hand design

Type	Art.no.
HERU®400 T EC CXLW 400V	997030120
HERU®400 T EC CXRW 400V	997030122
HERU®400 T EC CXLE 400V	997030124
HERU®400 T EC CXRE 400V	997030126



# ENERGY RECOVERY UNIT

## HERU®400 T EC



TECHNICAL DATA

HERU®400 T EC	LW	LE
<b>Voltage</b>	Y 400	Y 400 V
<b>Frequency</b>	50	50 Hz
<b>Phase</b>	3	3 ~
<b>Current, 2 fans</b>	4.65	4.65 A
<b>Current, electric heater</b>	–	9.10 A
<b>Total current</b>	5.40	14.50 A
<b>Power, 2 fans</b>	1069	1069 W
<b>Power, electric heater</b>	–	6300 W
<b>Total power</b>	1230	7530 W
<b>Speed</b>	2170	2170 rpm
<b>Enclosure class</b>	44	44 IP
<b>Sound pressure level, 3 m</b>	52	52 dB L <sub>PA</sub>
<b>Weight</b>	241	245 kg

### SOUND DATA (dB)

	Total (L <sub>wa</sub> )	63 Hz	125 Hz	250 Hz	500 Hz	1k Hz	2k Hz	4k Hz	8k Hz
<b>10 V / 420 l/s</b>									
Surrounding	59	46	52	56	45	41	46	45	34
Supply air	78	57	68	76	70	64	66	62	54
Extract air	70	55	62	69	51	43	44	35	22
<b>9.5 V / 385 l/s</b>									
Surrounding	57	44	52	53	43	40	44	45	34
Supply air	77	57	67	75	67	62	64	59	52
Extract air	70	54	62	69	49	41	43	34	20
<b>8.5 V / 355 l/s</b>									
Surrounding	54	43	52	46	41	36	41	43	31
Supply air	73	57	64	71	63	59	61	56	48
Extract air	68	54	62	67	46	39	40	30	16
<b>8 V / 310 l/s</b>									
Surrounding	54	43	53	43	37	34	40	40	30
Supply air	70	57	64	67	61	58	60	54	46
Extract air	64	53	62	58	44	37	39	29	15
<b>7 V / 285 l/s</b>									
Surrounding	52	42	51	40	33	30	35	33	30
Supply air	67	56	60	63	57	54	56	49	40
Extract air	61	52	59	52	41	34	36	25	14
<b>6 V / 210 l/s</b>									
Surrounding	48	40	47	36	30	27	29	29	30
Supply air	62	53	55	58	51	48	52	44	34
Extract air	58	50	57	49	40	31	32	21	14

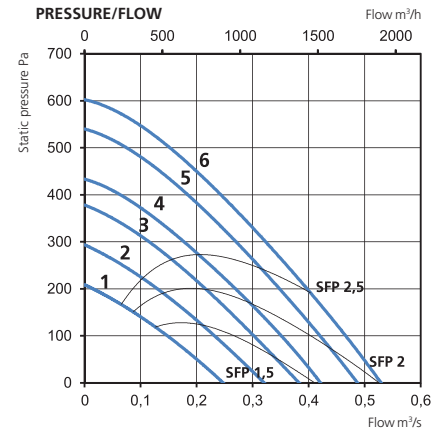

### POWER, FANS/FLOW

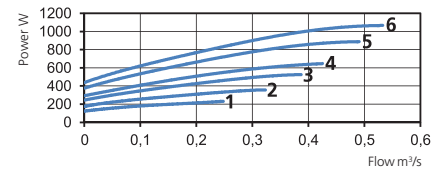

### TEMPERATURE EFFICIENCY

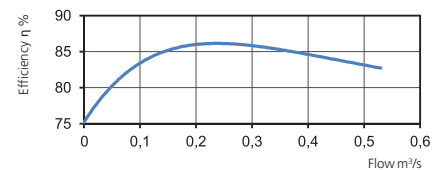

### CONTROL VOLTAGE

1	2	3	4	5	6
6V	7V	8V	8.5V	9.5V	10V

Pressure/airflow diagrams apply for both supply and extract air. Power and SFP apply for both of the fans together.



# ENERGY RECOVERY UNIT

## HERU®600 T EC

- Compact unit with top connection.
- Designed for supply and exhaust air ventilation with energy recovery.
- Suitable for installation in homes, offices and other premises where there are stringent requirements on the indoor environment.
- High temperature efficiency 86%, low energy consumption (SFP), low sound level, high operating reliability and provides clean indoor air.
- Unique design minimizes all thermal bridges.
- Can be ordered with integrated Siemens Climatix (CX) control equipment or without control equipment (ET).
- Comes prepared for Modbus communication via RS485 (accessory needed).
- Airflow is generated by two silent anti-vibration plug fans with EC motors and impellers with backward curved blades.

- The fans are connected with quick connectors and are very easy to remove for cleaning.
- Speed controlled rotating aluminum heat exchanger with adjustable hub and purge sector. The rotor can be removed for cleaning.
- Deep pleated filter ISO ePM1 65% as standard, for both exhaust and supply air. The filter is very easy to change.
- Available with integrated electric heater or heating coil.
- The water and electrical connections are positioned to facilitate practical and simple connection.
- The unit is made from aluminum-zinc-plated steel and insulated.
- For placement in both warm and cold environments.
- Available in either right-hand or left-hand design.
- Delivered with adjustable feet and Novibra mats.

### ACCESSORIES

- Filterkit ISO ePM1 65%
- Adjustable feet
- Novibra mat
- Control system
- Cooling coil
- Damper
- Flow meter
- U-pipe filter
- Valve actuator
- Shunt
- Water trap
- Silencer



### DIMENSIONS (mm)

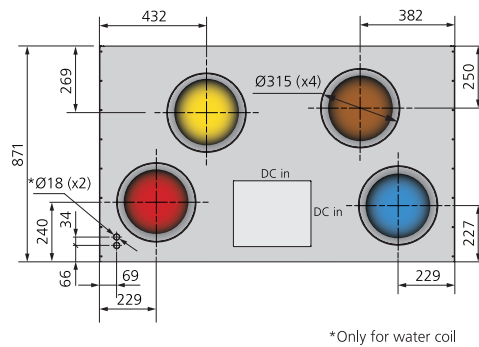
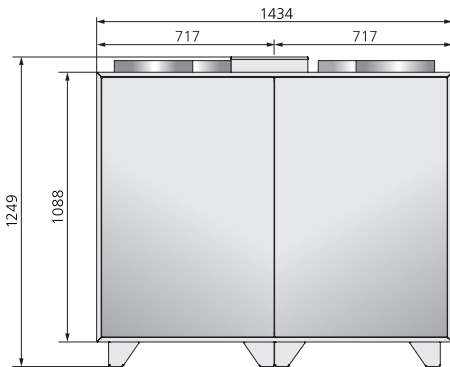
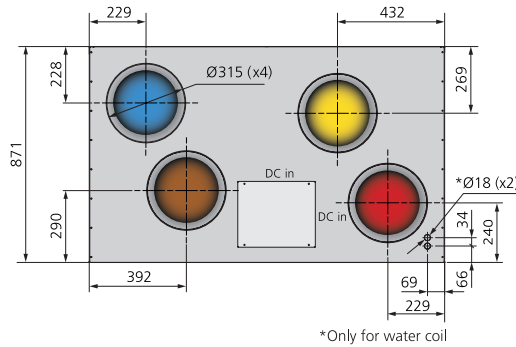
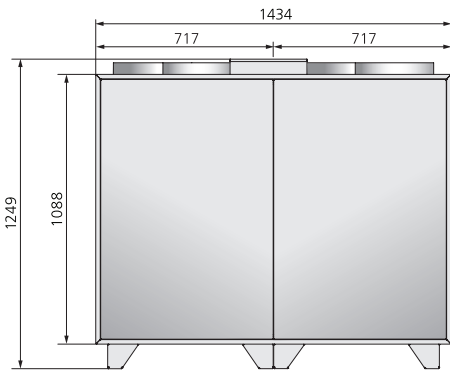

### CONNECTIONS

- Supply air
- Extract air
- Exhaust air
- Fresh air

Top connection

EC = Fans with low-energy motors

Capacity

400V = 3-phase

HERU®600T EC CX L W-400V

CX = Control system Siemens Climatix  
ET = Without control system, Routed to terminal block

W = Heater kit, water  
E = Electric heater

R = Right-hand design  
L = Left-hand design

Type	Art.no.
HERU®600 T EC CXLW 400V	997030220
HERU®600 T EC CXRW 400V	997030222
HERU®600 T EC CXLE 400V	997030224
HERU®600 T EC CXRE 400V	997030226

# ENERGY RECOVERY UNIT

## HERU®600 T EC



### TECHNICAL DATA

HERU®600 T EC	LW	LE
<b>Voltage</b>	Y 400	Y 400 V
<b>Frequency</b>	50	50 Hz
<b>Phase</b>	3	3 ~
<b>Current, 2 fans</b>	10.70	10.70 A
<b>Current, electric heater</b>	–	9.10 A
<b>Total current</b>	11.40	20.50 A
<b>Power, 2 fans</b>	2460	2460 W
<b>Power, electric heater</b>	–	6300 W
<b>Total power</b>	2630	8980 W
<b>Speed</b>	2900	2900 rpm
<b>Enclosure class</b>	44	44 IP
<b>Sound pressure level, 3 m</b>	54	54 dB L <sub>PA</sub>
<b>Weight</b>	251	255 kg

### SOUND DATA (dB)

	Total (L <sub>wa</sub> )	63 Hz	125 Hz	250 Hz	500 Hz	1k Hz	2k Hz	4k Hz	8k Hz
<b>10 V / 745 l/s</b>									
Surrounding	61	51	52	56	51	50	56	46	36
Supply air	86	59	63	81	74	74	83	76	68
Extract air	71	58	63	69	62	55	57	48	40
<b>9 V / 658 l/s</b>									
Surrounding	60	48	50	58	48	47	52	41	32
Supply air	85	57	62	81	73	71	80	72	65
Extract air	70	56	61	68	60	52	52	46	37
<b>8 V / 572 l/s</b>									
Surrounding	60	45	47	59	46	44	46	37	30
Supply air	81	54	63	78	72	69	73	68	60
Extract air	72	53	59	71	56	48	49	42	32
<b>7 V / 434 l/s</b>									
Surrounding	54	42	47	52	43	41	39	33	28
Supply air	76	51	67	72	66	67	69	64	56
Extract air	71	52	60	71	52	46	44	39	31
<b>6 V / 380 l/s</b>									
Surrounding	48	38	47	41	36	36	34	29	28
Supply air	71	49	64	65	60	63	63	58	51
Extract air	65	48	63	59	45	41	39	31	22
<b>5 V / 284 l/s</b>									
Surrounding	48	35	48	37	30	31	28	26	27
Supply air	65	48	59	60	54	56	56	51	43
Extract air	58	44	57	50	39	32	33	24	16

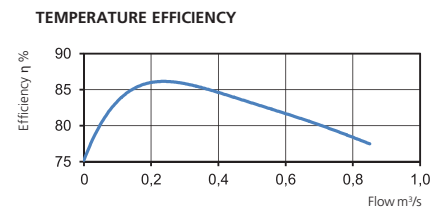
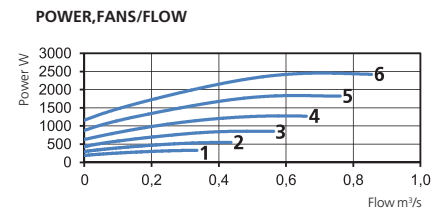
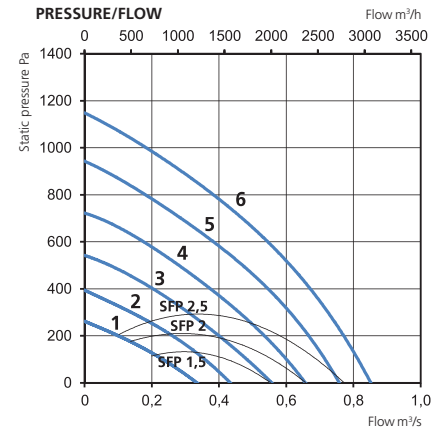

### CONTROL VOLTAGE

1	2	3	4	5	6
5V	6V	7V	8V	9V	10V

Pressure/airflow diagrams apply for both supply and extract air. Power and SFP apply for both of the fans together.

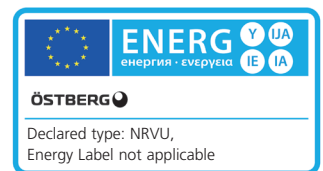



# ENERGY RECOVERY UNIT

## HERU®800 T EC

- Compact unit with top connection.
- Designed for supply and exhaust air ventilation with energy recovery.
- Suitable for installation in homes, offices and other premises where there are stringent requirements on the indoor environment.
- High temperature efficiency 86%, low energy consumption (SFP), low sound level, high operating reliability and provides clean indoor air.
- Unique design minimizes all thermal bridges.
- Can be ordered with integrated Siemens Climatix (CX) control equipment or without control equipment (ET).
- Comes prepared for Modbus communication via RS485 (accessory needed).
- Airflow is generated by two silent anti-vibration plug fans with EC motors and impellers with backward curved blades.

- The fans are connected with quick connectors and are very easy to remove for cleaning.
- Speed controlled rotating aluminum heat exchanger with adjustable hub and purge sector. The rotor can be removed for cleaning.
- Deep pleated filter ISO ePM1 65% as standard, for both exhaust and supply air. The filter is very easy to change.
- Available with integrated electric heater or heating coil.
- The water and electrical connections are positioned to facilitate practical and simple connection.
- The unit is made from aluminum-zinc-plated steel and insulated.
- For placement in both warm and cold environments.
- Available in either right-hand or left-hand design.
- Delivered with adjustable feet and Novibra mats.

### ACCESSORIES

- Filterkit ISO ePM1 65%
- Adjustable feet
- Novibra mat
- Control system
- Cooling coil
- Damper
- Flow meter
- U-pipe filter
- Valve actuator
- Shunt
- Water trap
- Silencer



### DIMENSIONS (mm)

#### RIGHT-HAND DESIGN

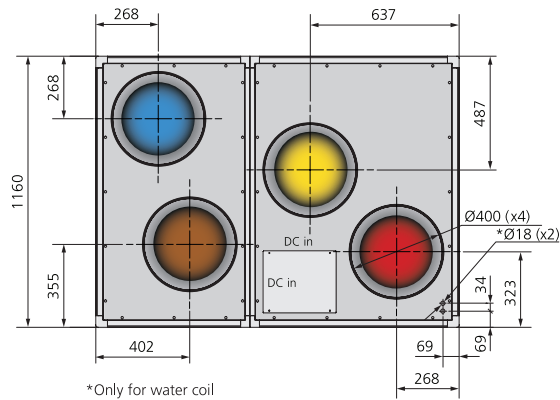
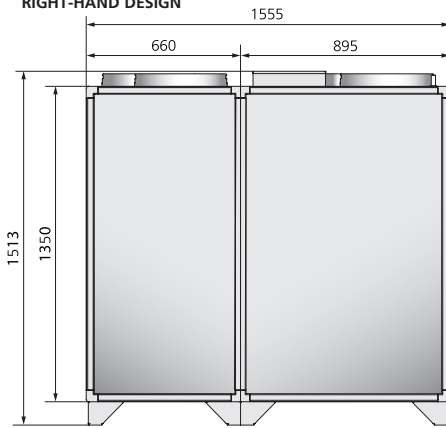

#### LEFT-HAND DESIGN

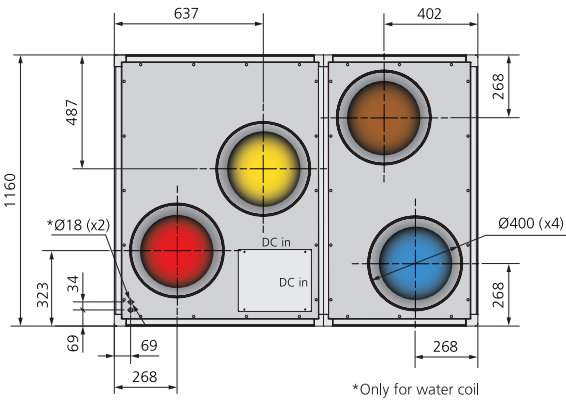
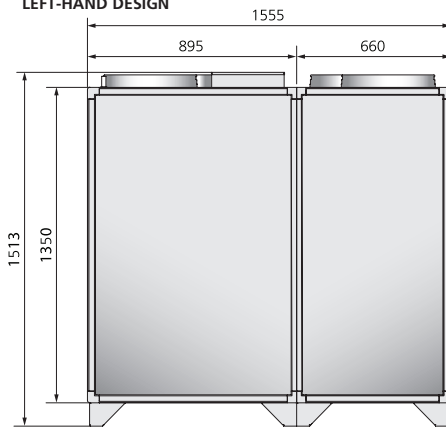

### CONNECTIONS

- Supply air
- Extract air
- Exhaust air
- Fresh air

Type	Art.no.
HERU®800 T EC CXLW 400V	997030128
HERU®800 T EC CXRW 400V	997030130
HERU®800 T EC CXLE 400V	997030132
HERU®800 T EC CXRE 400V	997030134

Top connection

EC = Fans with low-energy motors

Capacity

400V = 3-Phase

HERU®800T EC CX L W-400V

CX = Control system Siemens Climatix  
ET = Without control system, Routed to terminal block

W = Heater kit, water  
E = Electric heater

R = Right-hand design  
L = Left-hand design

# ENERGY RECOVERY UNIT

## HERU®800 T EC



### TECHNICAL DATA

HERU®800 T EC	LW	LE
<b>Voltage</b>	Y 400	Y 400 V
<b>Frequency</b>	50	50 Hz
<b>Phase</b>	3	3 ~
<b>Current, 2 fans</b>	3.80	3.80 A
<b>Current, electric heater</b>	–	14.30 A
<b>Total current</b>	4.10	18.40 A
<b>Power, 2 fans</b>	2630	2630 W
<b>Power, electric heater</b>	–	9900 W
<b>Total power</b>	2790	12690 W
<b>Speed</b>	2510	2510 rpm
<b>Enclosure class</b>	44	44 IP
<b>Sound pressure level, 3 m</b>	56	56 dB L <sub>PA</sub>
<b>Weight</b>	347	350 kg

### SOUND DATA (dB)

	Total (L <sub>wa</sub> )	63 Hz	125 Hz	250 Hz	500 Hz	1k Hz	2k Hz	4k Hz	8k Hz
<b>10 V / 960 l/s</b>									
Surrounding	63	55	59	60	49	48	49	49	35
Supply air	80	61	64	76	70	70	76	67	62
Extract air	71	58	60	68	65	60	53	46	37
<b>9.5 V / 900 l/s</b>									
Surrounding	62	52	58	60	47	47	47	47	34
Supply air	78	59	63	75	68	69	71	66	61
Extract air	69	56	58	66	63	58	54	45	36
<b>8.5 V / 770 l/s</b>									
Surrounding	62	50	56	60	44	43	43	44	31
Supply air	78	57	62	76	67	67	68	62	57
Extract air	71	54	57	70	60	54	49	42	32
<b>7 V / 660 l/s</b>									
Surrounding	58	45	57	51	38	38	37	37	29
Supply air	69	52	64	64	59	61	61	56	51
Extract air	62	50	59	58	53	45	44	35	24
<b>6 V / 530 l/s</b>									
Surrounding	58	41	58	44	34	35	34	33	29
Supply air	65	49	57	61	54	57	57	50	47
Extract air	58	47	55	52	48	40	39	30	19

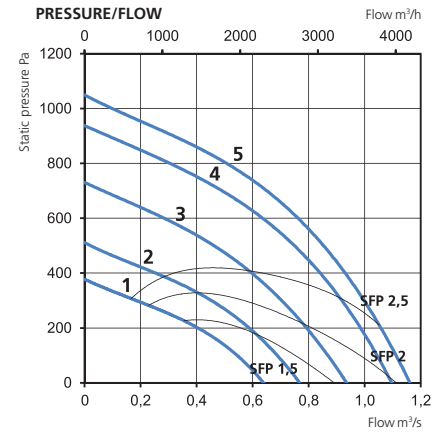

### POWER, FANS/FLOW

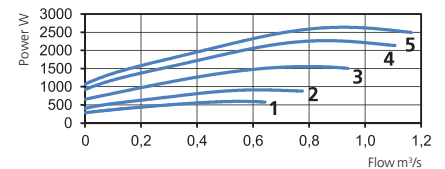

### TEMPERATURE EFFICIENCY

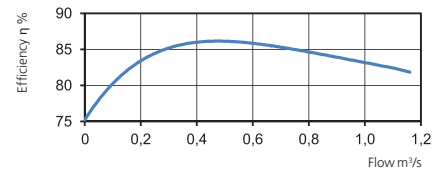

### CONTROL VOLTAGE

1	2	3	4	5
6V	7V	8.5V	9.5V	10V

Pressure/airflow diagrams apply for both supply and extract air. Power and SFP apply for both of the fans together.



# ENERGY RECOVERY UNIT

## HERU®1200 T EC

- Compact unit with top connection.
- Designed for supply and exhaust air ventilation with energy recovery.
- Suitable for installation in homes, offices and other premises where there are stringent requirements on the indoor environment.
- High temperature efficiency 86%, low energy consumption (SFP), low sound level, high operating reliability and provides clean indoor air.
- Unique design minimizes all thermal bridges.
- Can be ordered with integrated Siemens Climatix (CX) control equipment or without control equipment (ET).
- Comes prepared for Modbus communication via RS485 (accessory needed).
- Airflow is generated by two silent anti-vibration plug fans with EC motors and impellers with backward curved blades.

- The fans are connected with quick connectors and are very easy to remove for cleaning.
- Speed controlled rotating aluminum heat exchanger with adjustable hub and purge sector. The rotor can be removed for cleaning.
- Deep pleated filter ISO ePM1 65% as standard, for both exhaust and supply air. The filter is very easy to change.
- Available with integrated electric heater or heating coil.
- The water and electrical connections are positioned to facilitate practical and simple connection.
- The unit is made from aluminum-zinc-plated steel and insulated.
- For placement in both warm and cold environments.
- Available in either right-hand or left-hand design.
- Delivered with adjustable feet and Novibra mats.

### ACCESSORIES

- Filterkit ISO ePM1 65%
- Adjustable feet
- Novibra mat
- Control system
- Cooling coil
- Damper
- Flow meter
- U-pipe filter
- Valve actuator
- Shunt
- Water trap
- Silencer



### DIMENSIONS (mm)

#### RIGHT-HAND DESIGN

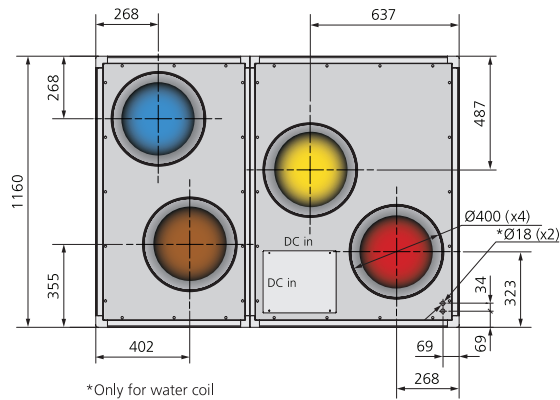
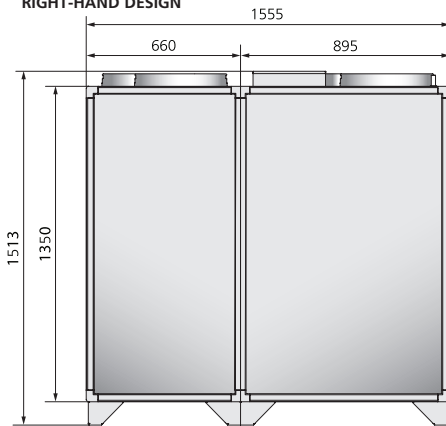

\*Only for water coil

#### LEFT-HAND DESIGN

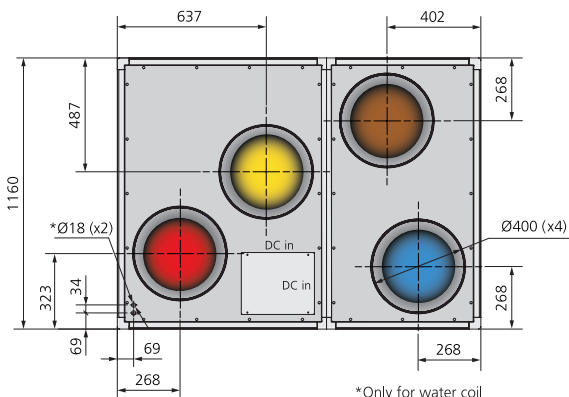
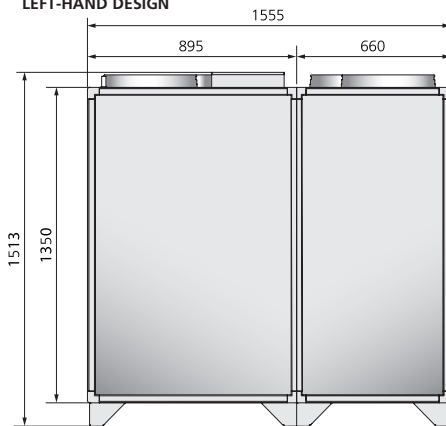

\*Only for water coil

### CONNECTIONS

- Supply air
- Extract air
- Exhaust air
- Fresh air

Type	Art.no.
HERU®1200 T EC CXLW 400V	997030176
HERU®1200 T EC CXRW 400V	997030177
HERU®1200 T EC CXLE 400V	997030178
HERU®1200 T EC CXRE 400V	997030179

Top connection

EC = Fans with low-energy motors

Capacity

400V = 3-Phase

# HERU®1200T EC CX L W-400V

CX = Control system Siemens Climatix  
ET = Without control system, Routed to terminal block

W = Heater kit, water  
E = Electric heater

R = Right-hand design  
L = Left-hand design



# ENERGY RECOVERY UNIT

## HERU®1200 T EC



### TECHNICAL DATA

HERU®1200 T EC	LW	LE
<b>Voltage</b>	Y 400	Y 400 V
<b>Frequency</b>	50	50 Hz
<b>Phase</b>	3	3 ~
<b>Current, 2 fans</b>	6.43	6.43 A
<b>Current, electric heater</b>	–	14.30 A
<b>Total current</b>	6.70	21.00 A
<b>Power, 2 fans</b>	4450	4450 W
<b>Power, electric heater</b>	–	9900 W
<b>Total power</b>	4620	14520 W
<b>Speed</b>	2970	2970 rpm
<b>Enclosure class</b>	44	44 IP
<b>Sound pressure level, 3 m</b>	65	65 dB L <sub>PA</sub>
<b>Weight</b>	351	354 kg

### SOUND DATA (dB)

	Total (L <sub>wa</sub> )	63 Hz	125 Hz	250 Hz	500 Hz	1k Hz	2k Hz	4k Hz	8k Hz
<b>10 V / 1122 l/s</b>									
Surrounding	72	59	66	67	60	61	64	59	47
Supply air	92	68	73	85	83	87	86	80	73
Extract air	78	69	71	75	68	66	65	57	48
<b>9 V / 1020 l/s</b>									
Surrounding	70	58	65	66	58	59	61	56	41
Supply air	90	69	72	83	81	85	83	77	69
Extract air	76	66	69	73	65	64	61	54	45
<b>8 V / 909 l/s</b>									
Surrounding	67	55	63	63	54	55	57	52	37
Supply air	87	64	70	82	78	81	79	73	65
Extract air	73	63	67	70	61	60	58	50	41
<b>7 V / 797 l/s</b>									
Surrounding	65	53	61	61	50	51	52	46	32
Supply air	82	62	68	77	73	77	74	68	60
Extract air	71	61	65	67	58	56	54	46	36
<b>6 V / 657 l/s</b>									
Surrounding	61	50	58	57	46	46	47	41	28
Supply air	78	59	65	73	70	72	69	63	54
Extract air	69	59	62	67	53	51	49	40	30
<b>5 V / 525 l/s</b>									
Surrounding	56	47	54	50	40	40	41	34	26
Supply air	72	57	63	66	63	67	63	56	47
Extract air	63	55	60	57	46	45	42	33	21
<b>4 V / 381 l/s</b>									
Surrounding	50	43	48	43	33	33	33	28	26
Supply air	66	53	58	60	56	61	55	48	37
Extract air	57	52	53	50	38	38	34	24	12

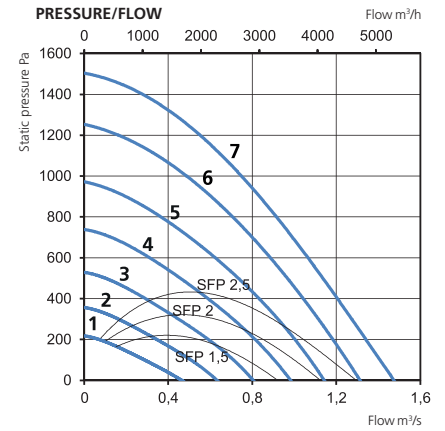

### POWER, FANS/FLOW

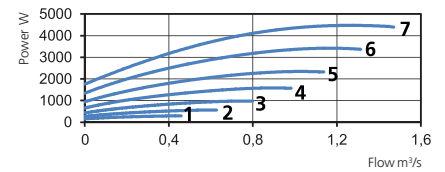

### TEMPERATURE EFFICIENCY

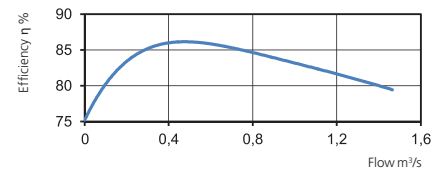

### CONTROL VOLTAGE

1	2	3	4	5	6	7
4V	5V	6V	7V	8V	9V	10V

Pressure/airflow diagrams apply for both supply and extract air. Power and SFP apply for both of the fans together.



# ENERGY RECOVERY UNIT

## HERU®50 LP EC

- Energy recovery unit with low profile and side connections. Ideal for mounting in small spaces such as in the ceiling.
- Designed for supply and exhaust air ventilation with energy recovery.
- Suitable for installation in homes, offices and other premises where there are stringent requirements on the indoor environment.
- High temperature efficiency 82%, low energy consumption (SFP), low sound level, high operating reliability and provides clean indoor air.
- Unique design minimizes all thermal bridges.
- For easy handling, the unit is remote-controlled using the wireless control unit for operation and monitoring.
- Comes prepared for Modbus communication via RS485 (accessory needed).

- Airflow is generated by two silent radial fans with EC motors and impellers with forward curved blades.
- The fans are connected with quick connectors and are very easy to remove for cleaning.
- A regenerative, non-hygroscopic, aluminum rotating heat exchanger located in the center of the unit. The heat exchanger can also be removed for cleaning.
- Comes with panel filter ISO ePM1 50% as standard, for both exhaust and supply air. The filter is very easy to change.
- Integrated controls for heating/cooling.
- Available with or without integrated electric heater.
- The unit is constructed of double-layer galvanized steel sheet with insulation in between.
- For placement in warm areas.
- Available in either right-hand or left-hand design.

### ACCESSORIES

- Filterkit ISO ePM1 50%
- Outside wall hood 160
- Remote Control with Modbus
- Control board
- Heater Kit Water, Relay pump control
- Pressure Sensor Kit
- Damper motor
- Carbon dioxide sensor CO2
- Humidity sensor RH
- Room sensor
- Duct sensor
- Freeze protection sensor
- Extension cable to antenna
- Silencer LDC 125



### DIMENSIONS (mm)

#### RIGHT-HAND DESIGN

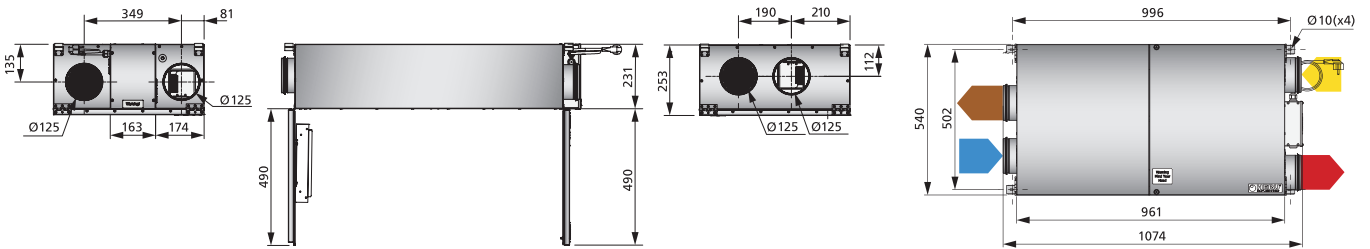

#### LEFT-HAND DESIGN

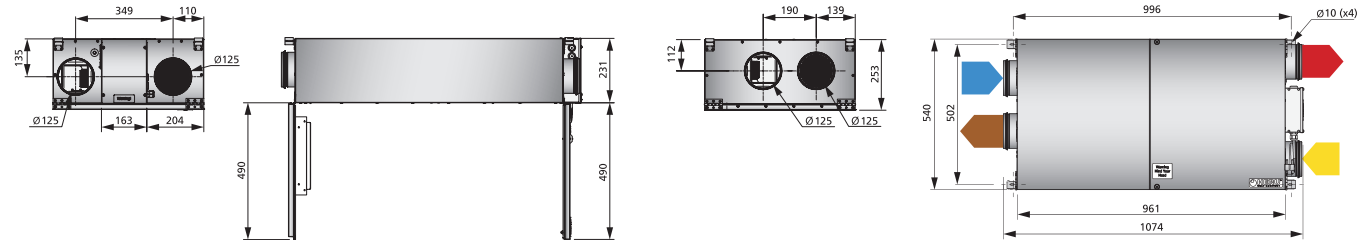

### CONNECTIONS

- Supply air (Red arrow)
- Extract air (Yellow arrow)
- Exhaust air (Brown arrow)
- Fresh air (Blue arrow)

Type	Art.no.
HERU®50 LP EC AR	8010744
HERU®50 LP EC AL	8010745
HERU®50 LP EC CR	8010746
HERU®50 LP EC CL	8010747

Low profile

Capacity

EC = Fans with low-energy motors

# HERU®50 LP EC AR

A = Integrated electric heater  
C = Without electric heater

R = Right-hand design  
L = Left-hand design



# ENERGY RECOVERY UNIT

## HERU<sup>®</sup>50 LP EC

### TECHNICAL DATA

HERU <sup>®</sup> 50 LP EC	A	C
Voltage	230	230 V
Frequency	50	50 Hz
Phase	1	1 ~
Current, 2 fans	1.02	1.02 A
Current, electric heater	3.91	- A
Total current	5.00	1.12 A
Power, 2 fans	115	115 W
Power, electric heater	900	- W
Total power	1040	142 W
Speed	3400	3400 rpm
Enclosure class	41	41 IP
Sound pressure level, 3 m	41	41 dB LpA
Weight	46	45 kg
Wiring diagram	4040201	4040201

### SOUND DATA (dB)

	Total (L <sub>wa</sub> )	63 Hz	125 Hz	250 Hz	500 Hz	1k Hz	2k Hz	4k Hz	8k Hz
<b>10 V / 40 l/s</b>									
Surrounding	48	37	44	45	34	30	28	28	28
Supply air	71	59	61	64	64	65	63	58	56
Extract air	70	58	59	63	64	63	61	57	54
<b>8 V / 37 l/s</b>									
Surrounding	46	35	42	43	35	28	26	27	28
Supply air	69	58	59	61	62	63	60	56	52
Extract air	68	56	57	61	62	61	58	54	50
<b>6 V / 31 l/s</b>									
Surrounding	44	33	41	40	32	27	24	26	28
Supply air	66	55	55	59	59	60	56	51	46
Extract air	65	54	55	59	59	58	55	50	45
<b>4 V / 23 l/s</b>									
Surrounding	42	29	39	36	26	25	22	26	28
Supply air	62	53	52	55	55	56	51	46	38
Extract air	61	54	51	55	54	54	50	44	36
<b>2 V / 20 l/s</b>									
Surrounding	41	27	39	34	24	25	22	26	28
Supply air	59	51	49	52	52	53	47	42	32
Extract air	58	51	49	52	51	51	46	40	30

### SUPPLY AIR:

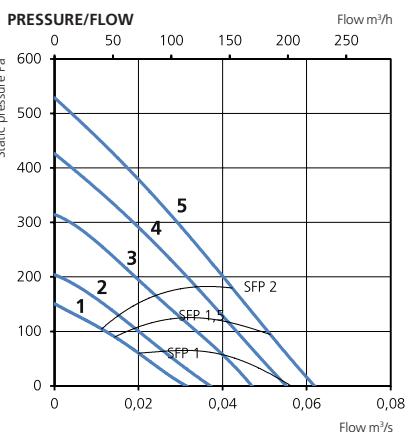

### EXTRACT AIR:

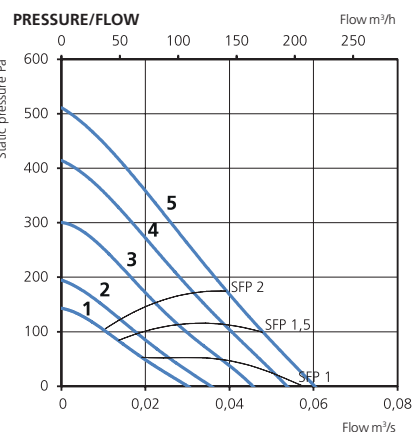

### POWER, FANS/FLOW

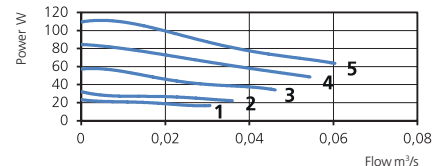

### TEMPERATURE EFFICIENCY

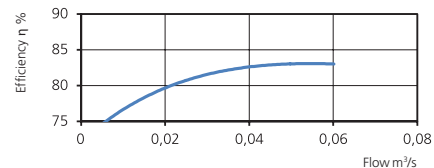

### CONTROL VOLTAGE

1	2	3	4	5
2V	4V	6V	8V	10V

Pressure/airflow diagrams apply for both supply and extract air. Power and SFP apply for both of the fans together.

**ENERG** energy energy  
**ÖSTBERG** HERU 50 LP EC  
 A+ A A B C D E F G → **A**  
 44 dB  
 183 m³/h  
 ENERGIA • ENERGIJA • ENERGIJA • ENERGIJA • ENERGIJA • ENERGIJA • ENERGIJA • ENERGIJA  
 2016 1254/2014

# ENERGY RECOVERY UNIT

## HERU®90 LP EC

- Energy recovery unit with low profile and side connections. Ideal for mounting in small spaces such in the ceiling.
- Designed for supply and exhaust air ventilation with energy recovery.
- Suitable for installation in homes, offices and other premises where there are stringent requirements on the indoor environment.
- High temperature efficiency 82%, low energy consumption (SFP), low sound level, high operating reliability and provides clean indoor air.
- Unique design minimizes all thermal bridges.
- For easy handling, the unit is remote-controlled using the wireless control unit for operation and monitoring.
- Comes prepared for Modbus communication via RS485 (accessory needed).
- Airflow is generated by two silent radial fans with EC motors and impellers with forward curved blades.

- The fans are connected with quick connectors and are very easy to remove for cleaning.
- A regenerative, non-hygroscopic, aluminum rotating heat exchanger located in the center of the unit. The heat exchanger can also be removed for cleaning.
- Comes with panel filter ISO ePM1 50% as standard, for both exhaust and supply air. The filter is very easy to change.
- Integrated controls for heating/cooling.
- Available with or without integrated electric heater.
- The unit is constructed of double-layer galvanized steel sheet with insulation in between.
- For placement in warm areas.
- Available in either right-hand or left-hand design.
- Can be ordered with a connection for a cooker hood. This connection is routed past the rotor to prevent cooking odours from spreading back into the premises.

### ACCESSORIES

- Filterkit ISO ePM1 50%
- Outside wall hood 160
- Remote Control with Modbus
- Control board
- Heater Kit Water
- Relay pump control
- Pressure Sensor Kit
- Damper motor
- Carbon dioxide sensor CO2
- Humidity sensor RH
- Room sensor
- Duct sensor
- Freeze protection sensor
- Extension cable to antenna
- Silencer LDC 125



### DIMENSIONS (mm)

#### RIGHT-HAND DESIGN

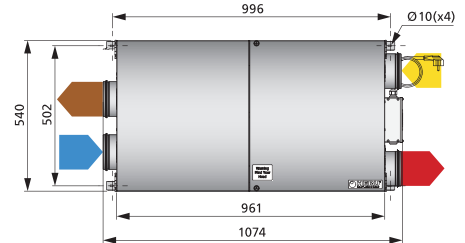
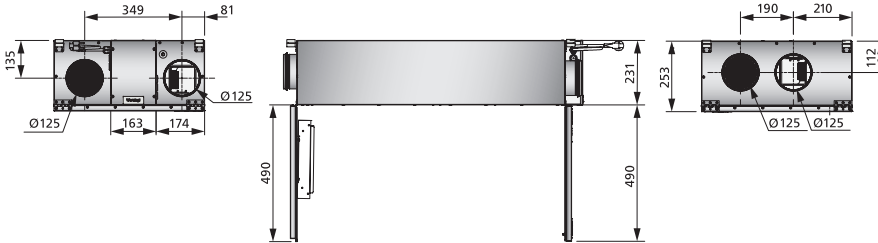

#### RIGHT-HAND DESIGN WITH COOKER HOOD CONNECTION

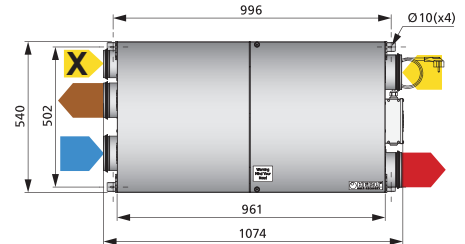

#### LEFT-HAND DESIGN

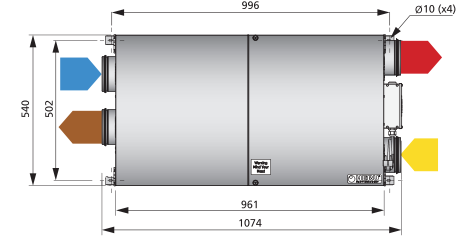

#### LEFT-HAND DESIGN WITH COOKER HOOD CONNECTION

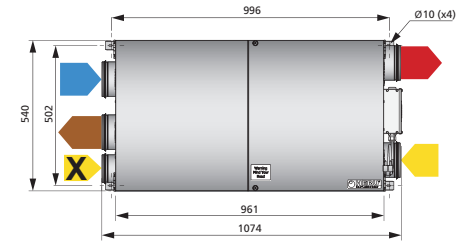

### CONNECTIONS

- Supply air
- Extract air
- Exhaust air
- Fresh air
- Cooker hood

Type	Art.no.
HERU®90 LP EC ARC	8010736
HERU®90 LP EC ALC	8010737
HERU®90 LP EC AR	8010738
HERU®90 LP EC AL	8010739
HERU®90 LP EC CR	8010740
HERU®90 LP EC CL	8010741

Low profile

EC = Fans with low-energy motors

Capacity

Cooker hood connection

**HERU®90 LP EC ARC**

A = Integrated electric heater  
C = Without electric heater

R = Right-hand design  
L = Left-hand design





# ENERGY RECOVERY UNIT

## HERU<sup>®</sup>90 LP EC

### TECHNICAL DATA

HERU <sup>®</sup> 90 LP EC	A	C
Voltage	230	230 V
Frequency	50	50 Hz
Phase	1	1 ~
Current, 2 fans	1.89	1.89 A
Current, electric heater	3.91	- A
Total current	5.90	1.99 A
Power, 2 fans	242	242 W
Power, electric heater	900	- W
Total power	1170	269 W
Speed	2710	2710 rpm
Enclosure class	41	41 IP
Sound pressure level, 3 m	46	46 dB LpA
Weight	46	45 kg
Wiring diagram	4040200	4040200

### SOUND DATA (dB)

	Total (L <sub>wa</sub> )	63 Hz	125 Hz	250 Hz	500 Hz	1k Hz	2k Hz	4k Hz	8k Hz
<b>10 V / 84 l/s</b>									
Surrounding	53	33	47	51	44	36	35	33	31
Supply air	77	64	63	68	70	70	72	67	67
Extract air	61	51	58	56	47	45	43	33	23
<b>8 V / 79 l/s</b>									
Surrounding	52	32	44	50	43	35	34	32	30
Supply air	76	60	62	66	68	68	70	65	65
Extract air	60	50	57	55	46	45	41	32	22
<b>6 V / 68 l/s</b>									
Surrounding	50	30	42	48	39	33	31	30	29
Supply air	73	58	59	63	65	66	66	62	61
Extract air	57	47	53	53	45	42	37	30	17
<b>4 V / 54 l/s</b>									
Surrounding	45	25	38	43	35	31	27	27	28
Supply air	68	55	56	60	61	63	60	57	54
Extract air	53	41	50	49	40	38	32	25	11
<b>2 V / 38 l/s</b>									
Surrounding	40	19	31	38	29	26	23	26	28
Supply air	62	52	51	54	54	57	52	48	41
Extract air	47	35	43	43	35	32	25	18	4

### SUPPLY AIR:

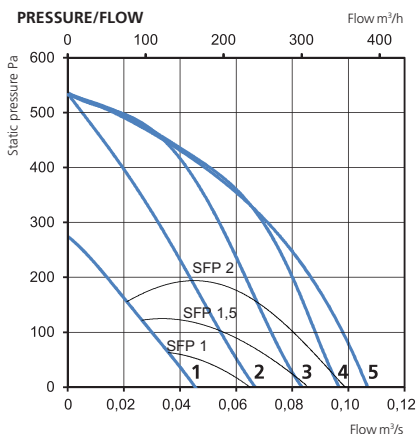

### EXTRACT AIR:

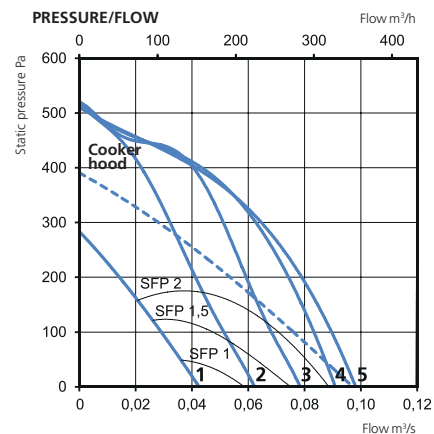

### POWER, FANS/FLOW

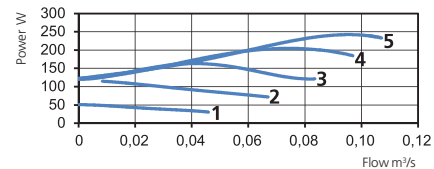

### TEMPERATURE EFFICIENCY

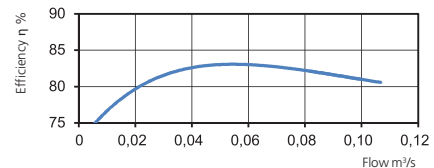

### CONTROL VOLTAGE

1	2	3	4	5
2V	4V	6V	8V	10V

Pressure/airflow diagrams apply for both supply and extract air. Power and SFP apply for both of the fans together.

ENERGIA - ENERGIJA - ENERGIJA - ENERGIJA - ENERGIJA - ENERGIJA - ENERGIJA - ENERGIJA  
**ÖSTBERG** HERU 90 LP EC  
 A+ A B C D E F G → **A**  
 49 dB 353 m<sup>3</sup>/h  
 ENERGIJA - ENERGIJA - ENERGIJA - ENERGIJA - ENERGIJA - ENERGIJA - ENERGIJA - ENERGIJA  
 2016 1254/2014

# ENERGY RECOVERY UNIT

## HERU®100 S EC 2

- Model with side connections.
- Designed for supply and extract air ventilation with energy recovery.
- Suitable for installation in apartments, small houses, offices and other premises where there are stringent requirements on the indoor environment.
- High temperature efficiency 86%, low energy consumption (SFP), low sound level, high operating reliability and provides clean indoor air.
- Unique design minimizes all thermal bridges.
- For easy handling, the unit is remote-controlled using the wireless control unit for operation and monitoring.
- Comes prepared for Modbus communication via RS485 (accessory needed).
- Airflow is generated by two silent radial fans with EC motors and impellers with backward curved blades.

- The fans are connected with quick connectors and are very easy to remove for cleaning.
- A regenerative, non-hygroscopic, aluminum rotating heat exchanger located in the center of the unit. The heat exchanger can also be removed for cleaning.
- Comes with bag filter ISO ePM1 65% as standard, for both extract and supply air. The filter is very easy to change.
- Integrated controls for heating/cooling.
- Available with or without integrated electric heater.
- The unit is constructed of double-layer galvanized steel sheet with insulation in between, and comes unpainted.
- For placement in warm or cold areas.
- Comes in right-hand version as standard, but can easily be rebuilt to left-hand design.
- Equipped with wall plug.

### ACCESSORIES

- Filterkit ISO ePM1 65%
- Filter ISO 16890 Coarse 80%
- Outside wall hood 160
- Remote Control with Modbus
- Heater Kit Water
- Relay pump control
- Pressure Sensor Kit
- Damper motor
- Carbon dioxide sensor CO2
- Humidity sensor RH
- Room sensor
- Duct sensor
- Freeze protection sensor
- Extension cable to antenna
- Silencer LDC 160



### DIMENSIONS (mm)

#### RIGHT-HAND DESIGN

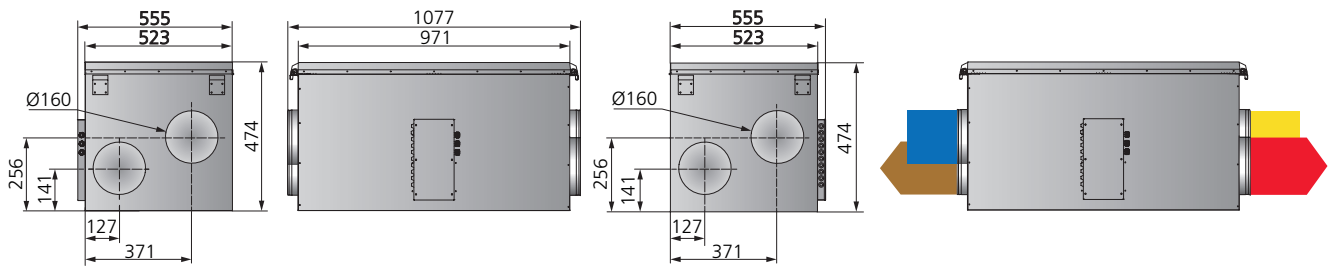

#### LEFT-HAND DESIGN

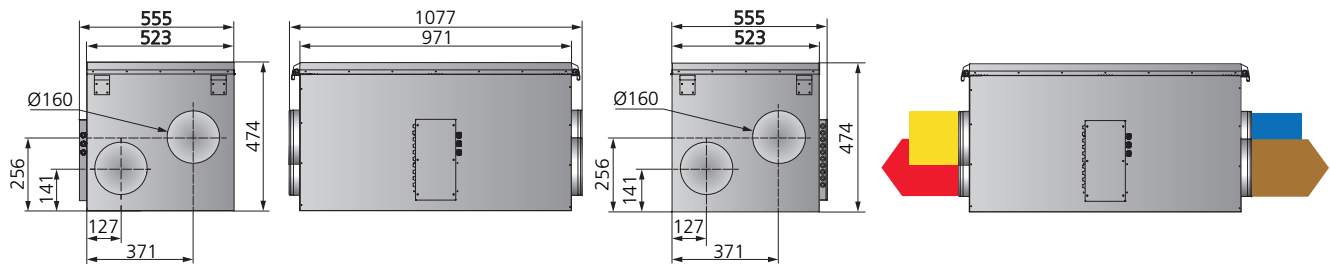

### CONNECTIONS

- Supply air
- Extract air
- Exhaust air
- Fresh air

Type	Art.no.
HERU®100 S EC 2 A 1200W	8010719
HERU®100 S EC 2 B 600W	8010720
HERU®100 S EC 2 C	8010721

Side connection

Capacity

EC = Fans with low-energy motors

**HERU®100S EC 2 A**

Version

Integrated electric heater with:

**A** = Full power

**B** = Half power

**C** = Without electric heater



# ENERGY RECOVERY UNIT

## HERU®100 S EC 2

### TECHNICAL DATA

HERU®100 S EC 2	A	B	C
<b>Voltage</b>	230	230	230 V
<b>Frequency</b>	50	50	50 Hz
<b>Phase</b>	1	1	1 ~
<b>Current, 2 fans</b>	1.67	1.67	1.67 A
<b>Current, electric heater</b>	5.22	2.61	- A
<b>Total current</b>	6.99	4.38	1.77 A
<b>Power, 2 fans</b>	209	209	209 W
<b>Power, electric heater</b>	1200	600	- W
<b>Total power</b>	1440	836	236 W
<b>Speed</b>	3580	3580	3580 rpm
<b>Enclosure class</b>	41	41	41 IP
<b>Sound pressure level, 3 m</b>	46	46	46 dB L <sub>PA</sub>
<b>Weight</b>	65	65	64 kg
<b>Wiring diagram</b>	4040181	4040181	4040181

### SOUND DATA (dB)

	Total (L <sub>WA</sub> )	63 Hz	125 Hz	250 Hz	500 Hz	1k Hz	2k Hz	4k Hz	8k Hz
<b>10 V / 93 l/s</b>									
Surrounding	53	41	44	44	51	41	36	31	28
Supply air	80	59	63	68	78	71	68	65	59
Extract air	63	51	56	59	58	51	44	36	22
<b>9 V / 86 l/s</b>									
Surrounding	53	37	43	43	51	39	34	29	28
Supply air	80	59	62	67	79	71	66	63	56
Extract air	63	50	55	57	60	52	42	34	20
<b>8 V / 76 l/s</b>									
Surrounding	48	34	41	44	43	36	30	28	28
Supply air	75	58	60	69	71	67	63	60	52
Extract air	60	49	53	56	54	46	39	31	16
<b>7 V / 66 l/s</b>									
Surrounding	44	33	39	40	37	32	26	26	27
Supply air	71	56	58	65	67	62	59	56	47
Extract air	57	47	51	54	50	43	36	28	12
<b>6 V / 55 l/s</b>									
Surrounding	41	30	37	37	33	30	24	26	27
Supply air	68	54	56	63	63	58	55	51	41
Extract air	55	45	48	53	46	39	33	23	8
<b>5 V / 45 l/s</b>									
Surrounding	40	29	33	36	29	29	23	25	27
Supply air	65	51	52	63	58	53	51	45	34
Extract air	51	43	45	46	43	35	29	18	5
<b>4 V / 34 l/s</b>									
Surrounding	37	25	30	31	27	28	22	25	27
Supply air	58	49	48	54	52	48	44	36	25
Extract air	51	40	42	50	39	30	23	11	4

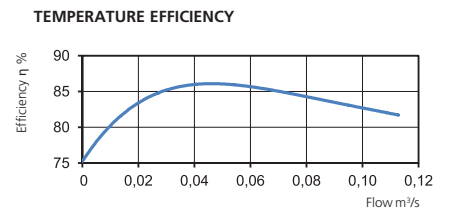
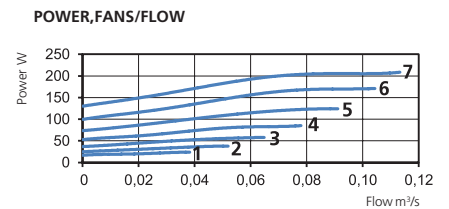
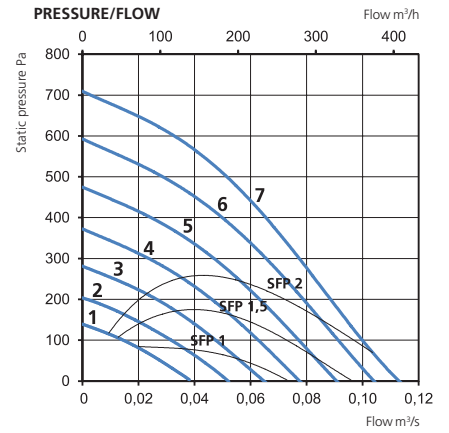

### CONTROL VOLTAGE

1	2	3	4	5	6	7
4V	5V	6V	7V	8V	9V	10V

Pressure/airflow diagrams apply for both supply and extract air. Power and SFP apply for both of the fans together.

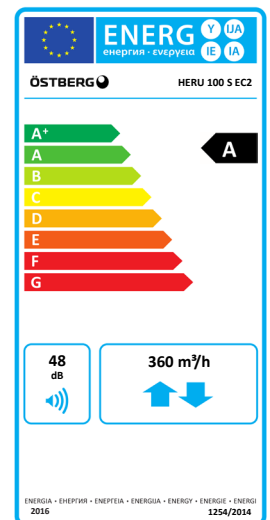

# ENERGY RECOVERY UNIT

## HERU®130 S EC 2

- Model with side connections.
- Designed for supply and extract air ventilation with energy recovery.
- Suitable for installation in apartments, small houses, offices and other premises where there are stringent requirements on the indoor environment.
- High temperature efficiency 86%, low energy consumption (SFP), low sound level, high operating reliability and provides clean indoor air.
- Unique design minimizes all thermal bridges.
- For easy handling, the unit is remote-controlled using the wireless control unit for operation and monitoring.
- Comes prepared for Modbus communication via RS485 (accessory needed).
- Airflow is generated by two silent radial fans with EC motors and impellers with backward curved blades.

- The fans are connected with quick connectors and are very easy to remove for cleaning.
- A regenerative, non-hygroscopic, aluminum rotating heat exchanger located in the center of the unit. The heat exchanger can also be removed for cleaning.
- Comes with bag filter ISO ePM1 65% as standard, for both extract and supply air. The filter is very easy to change.
- Integrated controls for heating/cooling.
- Available with or without integrated electric heater.
- The unit is constructed of double-layer galvanized steel sheet with insulation in between, and comes unpainted.
- For placement in warm or cold areas.
- Comes in right-hand version as standard, but can easily be rebuilt to left-hand design.
- Equipped with wall plug.

### ACCESSORIES

- Filterkit ISO ePM1 65%
- Filter ISO 16890 Coarse 80%
- Outside wall hood 200
- Remote Control with Modbus
- Heater Kit Water
- Relay pump control
- Pressure Sensor Kit
- Damper motor
- Carbon dioxide sensor CO2
- Humidity sensor RH
- Room sensor
- Duct sensor
- Freeze protection sensor
- Extension cable to antenna
- Silencer LDC 200



### DIMENSIONS (mm)

#### RIGHT-HAND DESIGN

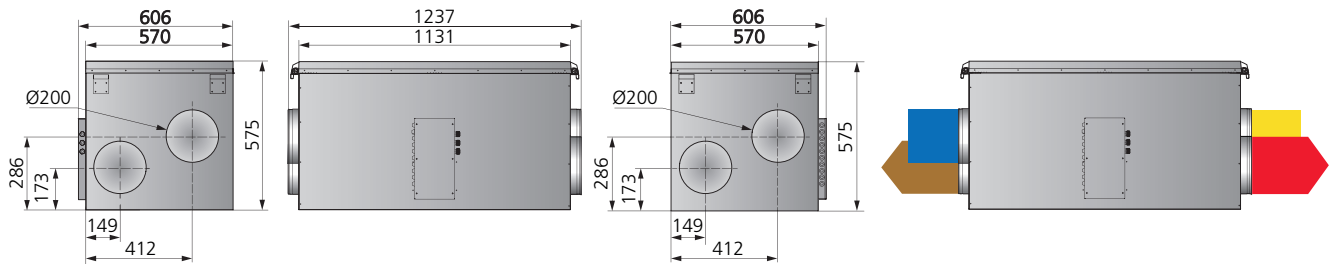

#### LEFT-HAND DESIGN

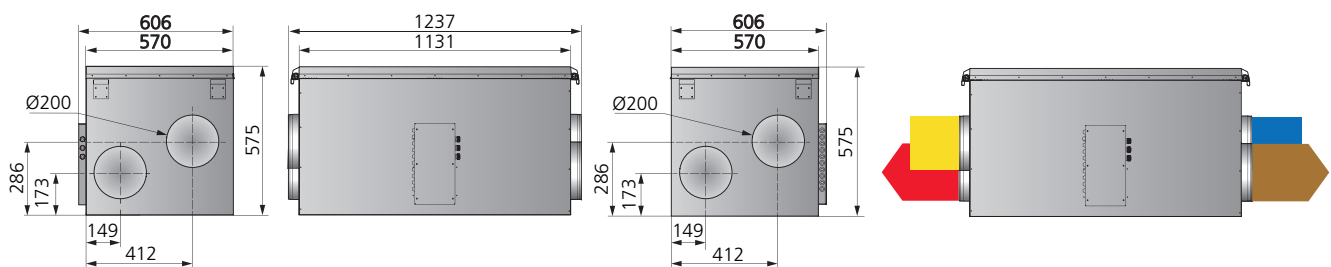

### CONNECTIONS

- Supply air
- Extract air
- Exhaust air
- Fresh air

Type	Art.no.
HERU®130 S EC 2 A 1700W	8010200
HERU®130 S EC 2 B 850W	8010201
HERU®130 S EC 2 C	8010202

Side connection

Capacity

EC = Fans with low-energy motors

**HERU®130S EC 2 A**

Version

Integrated electric heater with:

**A** = Full power

**B** = Half power

**C** = Without electric heater



# ENERGY RECOVERY UNIT

## HERU<sup>®</sup>130 S EC 2



### TECHNICAL DATA

HERU <sup>®</sup> 130 S EC 2	A	B	C
<b>Voltage</b>	230	230	230 V
<b>Frequency</b>	50	50	50 Hz
<b>Phase</b>	1	1	1 ~
<b>Current, 2 fans</b>	2.49	2.49	2.49 A
<b>Current, electric heater</b>	7.39	3.70	– A
<b>Total current</b>	10.00	6.30	2.59 A
<b>Power, 2 fans</b>	328	328	328 W
<b>Power, electric heater</b>	1700	850	– W
<b>Total power</b>	2060	1210	355 W
<b>Speed</b>	3080	3080	3080 rpm
<b>Enclosure class</b>	41	41	41 IP
<b>Sound pressure level, 3 m</b>	47	47	47 dB L <sub>PA</sub>
<b>Weight</b>	85	85	84 kg
<b>Wiring diagram</b>	4040164	4040164	4040164

### SOUND DATA (dB)

	Total (L <sub>WA</sub> )	63 Hz	125 Hz	250 Hz	500 Hz	1k Hz	2k Hz	4k Hz	8k Hz
<b>10 V / 158 l/s</b>									
Surrounding	54	46	50	50	44	40	38	33	30
Supply air	81	64	70	76	76	73	71	66	56
Extract air	68	55	64	64	61	51	45	35	21
<b>8 V / 127 l/s</b>									
Surrounding	50	45	46	46	41	37	35	31	30
Supply air	76	63	67	70	71	69	67	61	50
Extract air	66	54	60	63	56	47	41	31	20
<b>7 V / 100 l/s</b>									
Surrounding	47	41	42	43	39	34	31	29	29
Supply air	73	61	62	68	67	64	62	55	44
Extract air	62	51	57	59	52	43	37	27	20
<b>6 V / 77 l/s</b>									
Surrounding	44	37	38	41	35	30	27	27	29
Supply air	68	58	57	62	62	59	57	49	37
Extract air	60	47	51	58	48	40	33	24	20
<b>5 V / 58 l/s</b>									
Surrounding	39	34	33	35	30	28	25	27	29
Supply air	61	53	52	53	56	52	48	39	27
Extract air	51	41	46	46	43	37	29	20	20
<b>4 V / 38 l/s</b>									
Surrounding	36	28	30	28	28	27	24	27	29
Supply air	54	46	45	46	49	44	39	30	24
Extract air	46	36	41	40	39	34	25	20	20

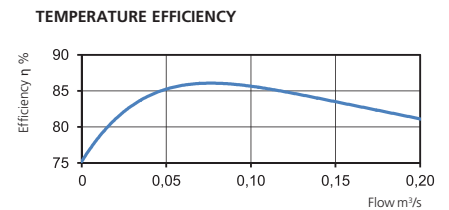
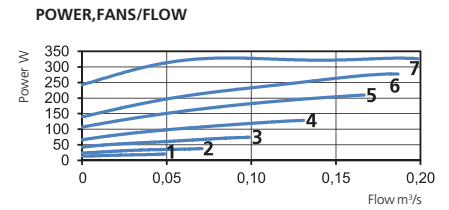
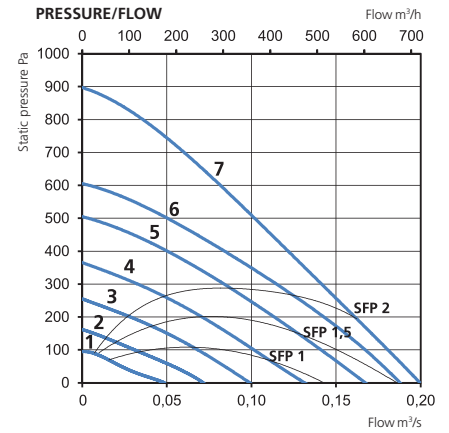

### CONTROL VOLTAGE

1	2	3	4	5	6	7
4V	5V	6V	7V	8V	8.5V	10V

Pressure/airflow diagrams apply for both supply and extract air. Power and SFP apply for both of the fans together.

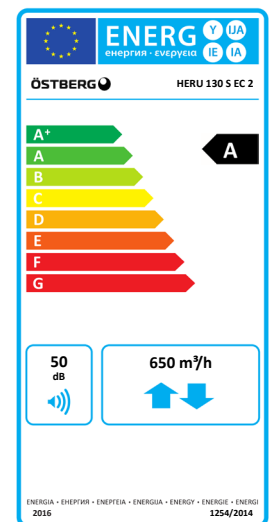

# ENERGY RECOVERY UNIT

## HERU®180 S EC 2

- Model with side connections.
- Designed for supply and extract air ventilation with energy recovery.
- Suitable for installation in apartments, small houses, offices and other premises where there are stringent requirements on the indoor environment.
- High temperature efficiency 86%, low energy consumption (SFP), low sound level, high operating reliability and provides clean indoor air.
- Unique design minimizes all thermal bridges.
- For easy handling, the unit is remote-controlled using the wireless control unit for operation and monitoring.
- Comes prepared for Modbus communication via RS485 (accessory needed).
- Airflow is generated by two silent radial fans with EC motors and impellers with backward curved blades.

- The fans are connected with quick connectors and are very easy to remove for cleaning.
- A regenerative, non-hygroscopic, aluminum rotating heat exchanger located in the center of the unit. The heat exchanger can also be removed for cleaning.
- Comes with bag filter ISO ePM1 65% as standard, for both extract and supply air. The filter is very easy to change.
- Integrated controls for heating/cooling.
- Available with or without integrated electric heater.
- The unit is constructed of double-layer galvanized steel sheet with insulation in between, and comes unpainted.
- For placement in warm or cold areas.
- Comes in right-hand version as standard, but can easily be rebuilt to left-hand design.

### ACCESSORIES

- Filterkit ISO ePM1 65%
- Filter ISO 16890 Coarse 80%
- Remote Control with Modbus
- Heater Kit Water
- Cooling coil Kit, Relay pump control
- Pressure Sensor Kit
- Damper motor
- Carbon dioxide sensor CO2
- Humidity sensor RH
- Room sensor
- Duct sensor
- Freeze protection sensor
- Extension cable to antenna
- Silencer LDC 250



### DIMENSIONS (mm)

#### RIGHT-HAND DESIGN

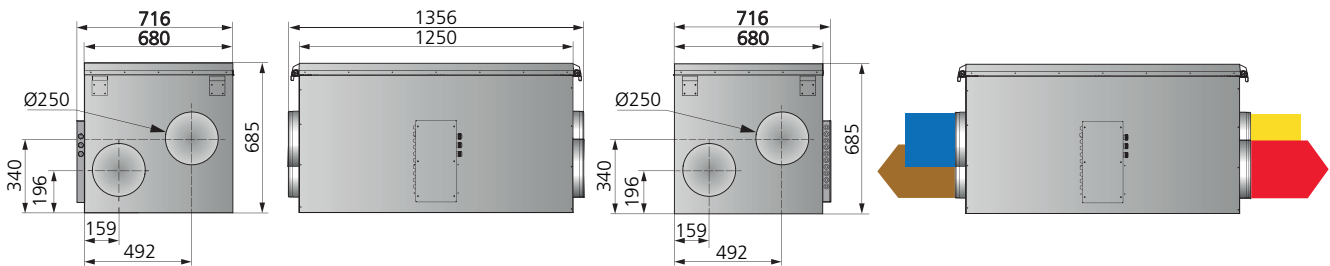

#### LEFT-HAND DESIGN

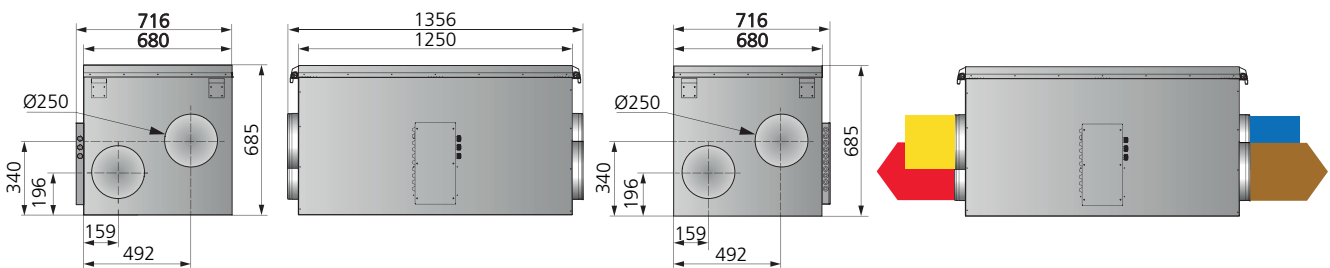

### CONNECTIONS

- Supply air
- Extract air
- Exhaust air
- Fresh air

Type	Art.no.
HERU®180 S EC 2A 2300W	8010240
HERU®180 S EC 2B 1150W	8010241
HERU®180 S EC 2C	8010242

### Side connection

Capacity

EC = Fans with low-energy motors

HERU®180S EC 2 A

Version

Integrated electric heater with:  
**A** = Full power  
**B** = Half power  
**C** = Without electric heater



TECHNICAL DATA

HERU® 180 S EC 2	A	B	C
<b>Voltage</b>	230	230	230 V
<b>Frequency</b>	50	50	50 Hz
<b>Phase</b>	1	1	1 ~
<b>Current, 2 fans</b>	2.49	2.49	2.49 A
<b>Current, electric heater</b>	10.00	5.00	- A
<b>Total current</b>	12.60	7.60	2.59 A
<b>Power, 2 fans</b>	323	323	323 W
<b>Power, electric heater</b>	2300	1150	- W
<b>Total power</b>	2650	1500	350 W
<b>Speed</b>	3020	3020	3020 rpm
<b>Ingress Protection rating</b>	41	41	41 IP
<b>Sound pressure level, 3 m</b>	47	47	47 dB L <sub>PA</sub>
<b>Weight</b>	103	103	101 kg
<b>Wiring diagram</b>	4040166	4040166	4040166

SOUND DATA (dB)

	Total (L <sub>wa</sub> )	63 Hz	125 Hz	250 Hz	500 Hz	1k Hz	2k Hz	4k Hz	8k Hz
<b>10 V / 180 l/s</b>									
Surrounding	54	44	50	49	44	44	38	34	29
Supply air	81	62	69	76	74	74	73	67	57
Extract air	67	56	60	64	56	53	46	37	24
<b>8 V / 157 l/s</b>									
Surrounding	51	42	47	47	41	41	35	32	29
Supply air	79	61	66	75	71	71	70	64	53
Extract air	68	58	57	66	52	49	43	33	23
<b>7 V / 131 l/s</b>									
Surrounding	47	40	43	40	39	37	31	29	29
Supply air	73	60	62	66	67	67	65	58	46
Extract air	61	55	56	55	51	46	40	29	23
<b>6 V / 100 l/s</b>									
Surrounding	43	38	38	39	34	34	28	28	29
Supply air	69	59	57	64	63	62	60	51	39
Extract air	58	53	51	53	45	42	35	26	23
<b>5 V / 75 l/s</b>									
Surrounding	40	38	35	33	31	30	26	28	29
Supply air	64	55	58	56	58	56	53	43	31
Extract air	54	48	50	46	41	37	31	24	23
<b>4 V / 53 l/s</b>									
Surrounding	38	28	33	30	30	29	26	28	30
Supply air	56	47	49	49	52	48	43	33	26
Extract air	46	39	41	40	38	31	26	23	23

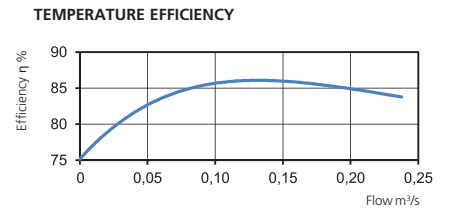
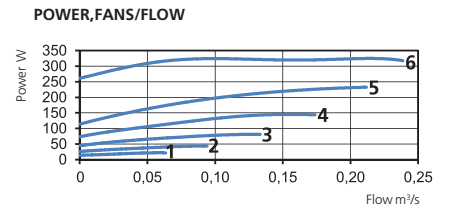
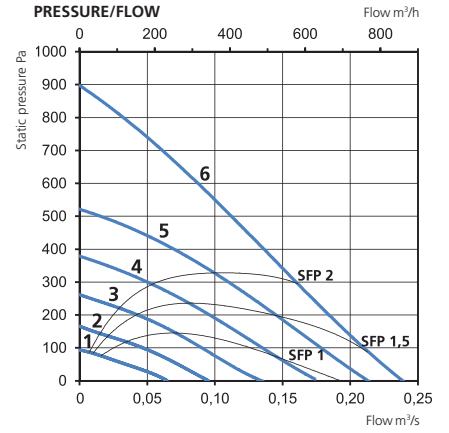

CONTROL VOLTAGE

1	2	3	4	5	6
4V	5V	6V	7V	8V	10V

Pressure/airflow diagrams apply for both supply and extract air. Power and SFP apply for both of the fans together.

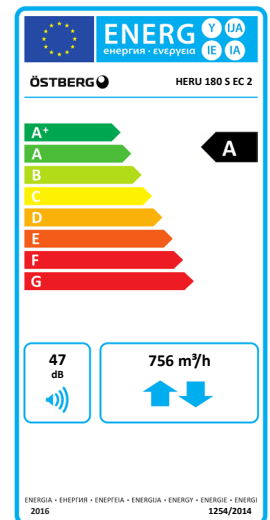

# ENERGY RECOVERY UNIT

## HERU®250 S EC 2

- Model with side connections.
- Designed for supply and extract air ventilation with energy recovery.
- Suitable for installation in apartments, small houses, offices and other premises where there are stringent requirements on the indoor environment.
- High temperature efficiency 86%, low energy consumption (SFP), low sound level, high operating reliability and provides clean indoor air.
- Unique design minimizes all thermal bridges.
- For easy handling, the unit is remote-controlled using the wireless control unit for operation and monitoring.
- Comes prepared for Modbus communication via RS485 (accessory needed).
- Airflow is generated by two silent radial fans with EC motors and impellers with backward curved blades.

- The fans are connected with quick connectors and are very easy to remove for cleaning.
- A regenerative, non-hygroscopic, aluminum rotating heat exchanger located in the center of the unit. The heat exchanger can also be removed for cleaning.
- Comes with bag filter ISO ePM1 65% as standard, for both extract and supply air. The filter is very easy to change.
- Integrated controls for heating/cooling.
- Available with or without integrated electric heater.
- The unit is constructed of double-layer galvanized steel sheet with insulation in between, and comes unpainted.
- For placement in warm or cold areas.
- Comes in right-hand version as standard, but can easily be rebuilt to left-hand design.

### ACCESSORIES

- Filterkit ISO ePM1 65%
- Filter ISO 16890 Coarse 80%
- Remote Control with Modbus
- Heater Kit Water
- Cooling coil Kit, Relay pump control
- Pressure Sensor Kit
- Damper motor
- Carbon dioxide sensor CO2
- Humidity sensor RH
- Room sensor
- Duct sensor
- Freeze protection sensor
- Extension cable to antenna
- Silencer LDC 250



### DIMENSIONS (mm)

#### RIGHT-HAND DESIGN

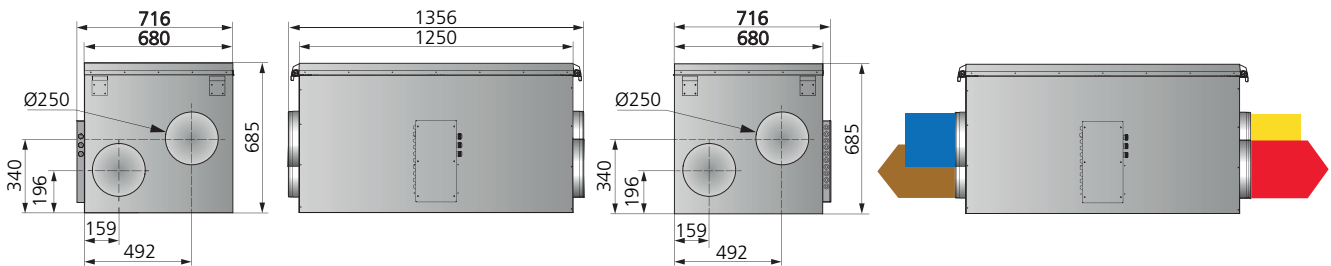

#### LEFT-HAND DESIGN

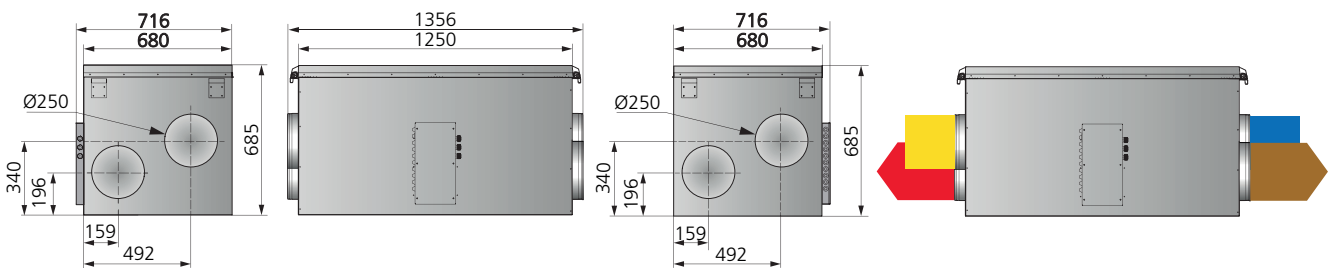

### CONNECTIONS

- Supply air
- Extract air
- Exhaust air
- Fresh air

Type	Art.no.
HERU®250 S EC 2 A 2300W	8010483
HERU®250 S EC 2 B 1150W	8010484
HERU®250 S EC 2 C	8010485

### Side connection

Capacity

EC = Fans with low-energy motors

HERU®250 S EC 2 A

Version

Integrated electric heater with:  
**A** = Full power  
**B** = Half power  
**C** = Without electric heater





TECHNICAL DATA

HERU®250 S EC 2	A	B	C
<b>Voltage</b>	230	230	230 V
<b>Frequency</b>	50	50	50 Hz
<b>Phase</b>	1	1	1 ~
<b>Current, 2 fans</b>	1.92	1.92	1.92 A
<b>Current, electric heater</b>	10.00	5.00	- A
<b>Total current</b>	12.00	7.00	2.02 A
<b>Power, 2 fans</b>	431	431	431 W
<b>Power, electric heater</b>	2300	1150	- W
<b>Total power</b>	2760	1610	458 W
<b>Speed</b>	2780	2780	2780 rpm
<b>Enclosure class</b>	41	41	41 IP
<b>Sound pressure level, 3 m</b>	46	46	46 dB L <sub>PA</sub>
<b>Weight</b>	108	108	106 kg
<b>Wiring diagram</b>	4040166	4040166	4040166

SOUND DATA (dB)

	Total (L <sub>WA</sub> )	63 Hz	125 Hz	250 Hz	500 Hz	1k Hz	2k Hz	4k Hz	8k Hz
<b>10 V / 220 l/s</b>									
Surrounding	51	47	45	45	45	41	38	35	30
Supply air	81	58	64	69	77	74	74	68	63
Extract air	63	51	57	60	55	51	43	34	24
<b>9 V / 216 l/s</b>									
Surrounding	50	44	45	44	44	40	37	34	30
Supply air	80	56	63	68	77	73	73	67	62
Extract air	62	50	56	59	54	51	42	33	24
<b>8.5 V / 196 l/s</b>									
Surrounding	49	38	43	43	43	39	35	32	29
Supply air	79	54	61	66	77	71	70	65	59
Extract air	61	49	54	57	54	48	40	32	24
<b>8 V / 174 l/s</b>									
Surrounding	48	36	42	42	42	38	33	31	29
Supply air	76	52	59	64	73	69	68	62	55
Extract air	59	47	51	56	54	45	38	30	24
<b>7 V / 153 l/s</b>									
Surrounding	46	35	39	40	41	35	32	30	29
Supply air	73	51	57	63	69	67	66	60	52
Extract air	57	46	49	53	53	43	36	28	24
<b>6 V / 142 l/s</b>									
Surrounding	44	34	38	39	38	33	29	29	29
Supply air	71	50	56	63	66	64	64	58	49
Extract air	56	44	50	53	49	41	34	27	24
<b>5 V / 123 l/s</b>									
Surrounding	43	33	35	41	34	31	28	28	29
Supply air	68	51	54	64	62	60	60	55	45
Extract air	55	47	47	52	44	38	32	26	24

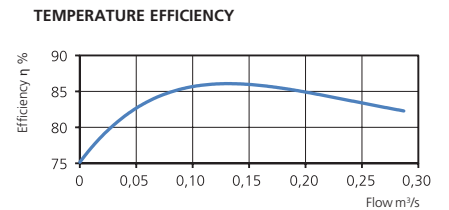
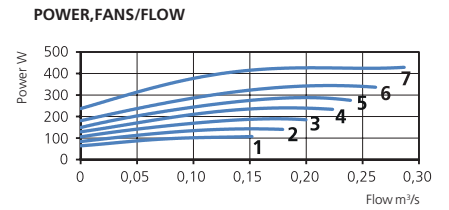
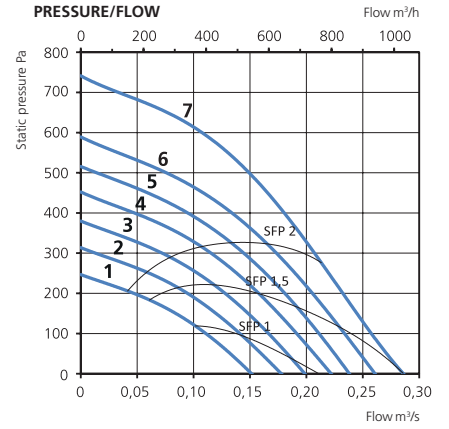

CONTROL VOLTAGE

1	2	3	4	5	6	7
5V	6V	7V	8V	8.5V	9V	10V

Pressure/airflow diagrams apply for both supply and extract air. Power and SFP apply for both of the fans together.

# ENERGY RECOVERY UNIT

## HERU®400 S EC

- Compact unit with side connections.
- Designed for supply and exhaust air ventilation with energy recovery.
- Suitable for installation in homes, offices and other premises where there are stringent requirements on the indoor environment.
- High temperature efficiency 86%, low energy consumption (SFP), low sound level, high operating reliability and provides clean indoor air.
- Unique design minimizes all thermal bridges.
- Can be ordered with integrated Siemens Climatix (CX) control equipment or without control equipment (ET). Comes prepared for Modbus communication via RS485 (accessory needed).
- Airflow is generated by two silent anti-vibration plug fans with EC motors and impellers with backward curved blades.

- The fans are connected with quick connectors and are very easy to remove for cleaning.
- Has a speed controlled rotating aluminum heat exchanger with adjustable hub and purge sector. The rotor can be removed for cleaning.
- Deep pleated filter ISO ePM1 65% as standard, for both exhaust and supply air. The filter is very easy to change.
- Available with integrated electric heater or heating coil.
- The water and electrical connections are positioned to facilitate practical and simple connection.
- The unit is made from aluminum-zinc-plated steel and insulated.
- For placement in both warm or cold environments.
- Available in either right-hand or left-hand design.
- Delivered with adjustable feet and Novibra mats.

### ACCESSORIES

- Filterkit ISO ePM1 65%
- Adjustable feet
- Novibra mat
- Control system
- Cooling coil
- Damper
- Flow meter
- U-pipe filter
- Valve actuator
- Shunt
- Water trap
- Silencer



### DIMENSIONS (mm)

#### RIGHT-HAND DESIGN

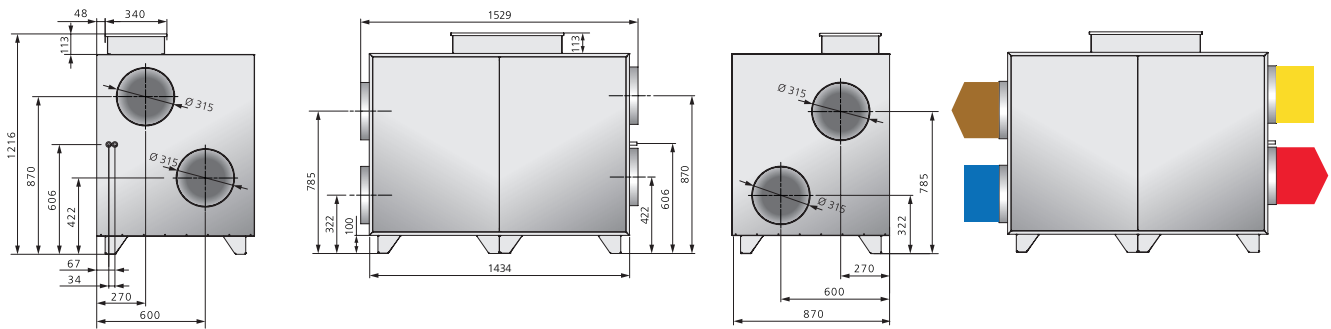

#### LEFT-HAND DESIGN

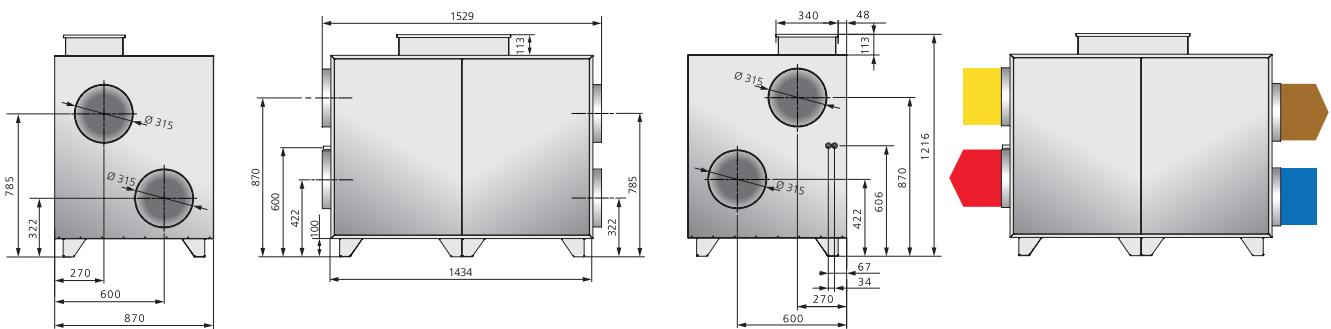

### CONNECTIONS

- Supply air
- Extract air
- Exhaust air
- Fresh air

Side connection

EC = Fans with low-energy motors

Capacity

400V = 3-Phase

**HERU®400S EC CX L W-400V**

CX = Control system Siemens Climatix

ET = Without control system, routed to terminal block

W = Heater kit, water

E = Electric heater

R = Right-hand design

L = Left-hand design

Type	Art.no.
HERU®400 S EC CXLW 400V	997080120
HERU®400 S EC CXRW 400V	997080122
HERU®400 S EC CXLE 400V	997080124
HERU®400 S EC CXRE 400V	997080126



# ENERGY RECOVERY UNIT

## HERU®400 S EC

### TECHNICAL DATA

HERU®400 S EC	LW	LE
<b>Voltage</b>	Y 400	Y 400 V
<b>Frequency</b>	50	50 Hz
<b>Phase</b>	3	3 ~
<b>Current, 2 fans</b>	4.65	4.65 A
<b>Current, electric heater</b>	-	9.10 A
<b>Total current</b>	5.40	14.50 A
<b>Power, 2 fans</b>	1069	1069 W
<b>Power, electric heater</b>	-	6300 W
<b>Total power</b>	1230	7530 W
<b>Speed</b>	2170	2170 rpm
<b>Enclosure class</b>	44	44 IP
<b>Sound pressure level, 3 m</b>	52	52 dB L <sub>PA</sub>
<b>Weight</b>	237	241 kg

### SOUND DATA (dB)

	Total (L <sub>wa</sub> )	63 Hz	125 Hz	250 Hz	500 Hz	1k Hz	2k Hz	4k Hz	8k Hz
<b>10 V / 420 l/s</b>									
Surrounding	59	46	52	56	45	41	46	45	34
Supply air	78	57	68	76	70	64	66	62	54
Extract air	70	55	62	69	51	43	44	35	22
<b>9.5 V / 385 l/s</b>									
Surrounding	57	44	52	53	43	40	44	45	34
Supply air	77	57	67	75	67	62	64	59	52
Extract air	70	54	62	69	49	41	43	34	20
<b>8.5 V / 355 l/s</b>									
Surrounding	54	43	52	46	41	36	41	43	31
Supply air	73	57	64	71	63	59	61	56	48
Extract air	68	54	62	67	46	39	40	30	16
<b>8 V / 310 l/s</b>									
Surrounding	54	43	53	43	37	34	40	40	30
Supply air	70	57	64	67	61	58	60	54	46
Extract air	64	53	62	58	44	37	39	29	15
<b>7 V / 285 l/s</b>									
Surrounding	52	42	51	40	33	30	35	33	30
Supply air	67	56	60	63	57	54	56	49	40
Extract air	61	52	59	52	41	34	36	25	14
<b>6 V / 210 l/s</b>									
Surrounding	48	40	47	36	30	27	29	29	30
Supply air	62	53	55	58	51	48	52	44	34
Extract air	58	50	57	49	40	31	32	21	14

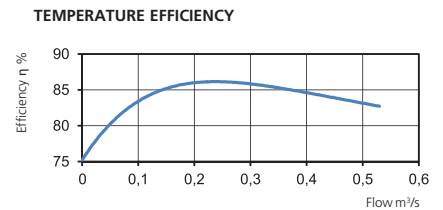
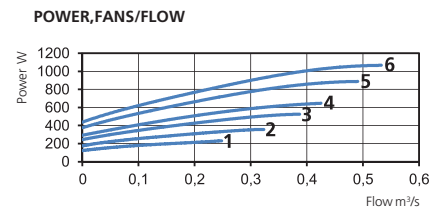
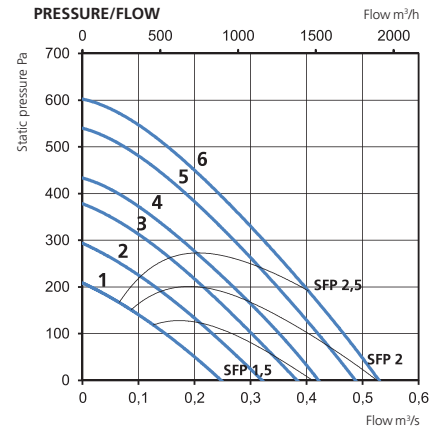

### CONTROL VOLTAGE

1	2	3	4	5	6
6V	7V	8V	8.5V	9.5V	10V

Pressure/airflow diagrams apply for both supply and extract air. Power and SFP apply for both of the fans together.



# ENERGY RECOVERY UNIT

## HERU®600 S EC

- Compact unit with side connections.
- Designed for supply and exhaust air ventilation with energy recovery.
- Suitable for installation in homes, offices and other premises where there are stringent requirements on the indoor environment.
- High temperature efficiency 86%, low energy consumption (SFP), low sound level, high operating reliability and provides clean indoor air.
- Unique design minimizes all thermal bridges.
- Can be ordered with integrated Siemens Climatix (CX) control equipment or without control equipment (ET). Comes prepared for Modbus communication via RS485 (accessory needed).
- Airflow is generated by two silent anti-vibration plug fans with EC motors and impellers with backward curved blades.

- The fans are connected with quick connectors and are very easy to remove for cleaning.
- Has a speed controlled rotating aluminum heat exchanger with adjustable hub and purge sector. The rotor can be removed for cleaning.
- Deep pleated filter ISO ePM1 65% as standard, for both exhaust and supply air. The filter is very easy to change.
- Available with integrated electric heater or heating coil.
- The water and electrical connections are positioned to facilitate practical and simple connection.
- The unit is made from aluminum-zinc-plated steel and insulated.
- For placement in both warm or cold environments.
- Available in either right-hand or left-hand design.
- Delivered with adjustable feet and Novibra mats.

### ACCESSORIES

- Filterkit ISO ePM1 65%
- Adjustable feet
- Novibra mat
- Control system
- Cooling coil
- Damper
- Flow meter
- U-pipe filter
- Valve actuator
- Shunt
- Water trap
- Silencer



### DIMENSIONS (mm)

#### RIGHT-HAND DESIGN

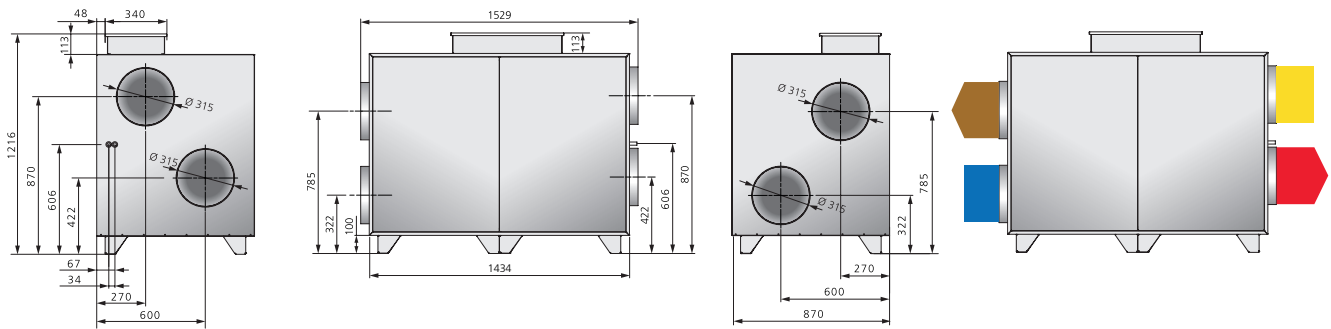

#### LEFT-HAND DESIGN

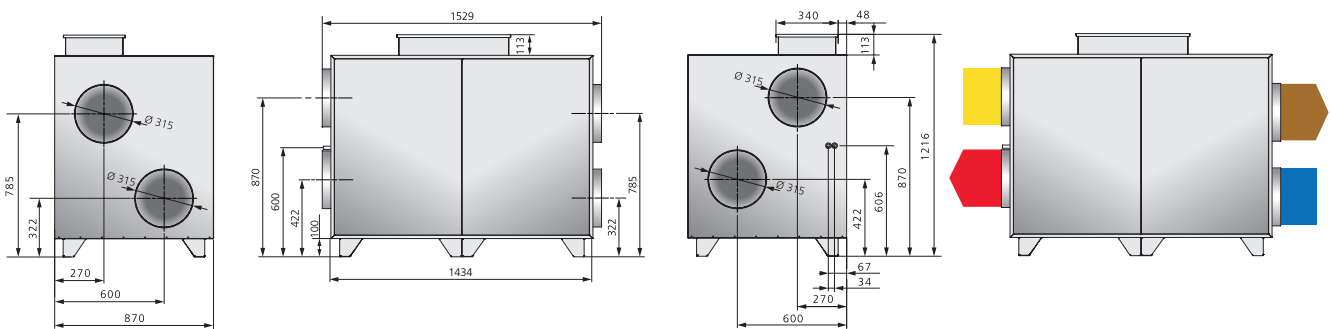

### CONNECTIONS

- Supply air
- Extract air
- Exhaust air
- Fresh air

Side connection

EC = Fans with low-energy motors

Capacity

400V = 3-Phase

**HERU®600S EC CX L W-400V**

CX = Control system Siemens Climatix  
ET = Without control system, routed to terminal block

W = Heater kit, water  
E = Electric heater

R = Right-hand design  
L = Left-hand design

Type	Art.no.
HERU®600 S EC CXLW 400V	997080176
HERU®600 S EC CXRW 400V	997080178
HERU®600 S EC CXLE 400V	997080180
HERU®600 S EC CXRE 400V	997080182





# ENERGY RECOVERY UNIT

## HERU®600 S EC

### TECHNICAL DATA

HERU®600 S EC	LW	LE
<b>Voltage</b>	Y 400	Y 400 V
<b>Frequency</b>	50	50 Hz
<b>Phase</b>	3	3 ~
<b>Current, 2 fans</b>	10.70	10.70 A
<b>Current, electric heater</b>	–	9.10 A
<b>Total current</b>	11.40	20.50 A
<b>Power, 2 fans</b>	2460	2460 W
<b>Power, electric heater</b>	–	6300 W
<b>Total power</b>	2630	8980 W
<b>Speed</b>	2900	2900 rpm
<b>Enclosure class</b>	44	44 IP
<b>Sound pressure level, 3 m</b>	54	54 dB L <sub>PA</sub>
<b>Weight</b>	247	251 kg

### SOUND DATA (dB)

	Total (L <sub>wa</sub> )	63 Hz	125 Hz	250 Hz	500 Hz	1k Hz	2k Hz	4k Hz	8k Hz
<b>10 V / 745 l/s</b>									
Surrounding	61	51	52	56	51	50	56	46	36
Supply air	86	59	63	81	74	74	83	76	68
Extract air	71	58	63	69	62	55	57	48	40
<b>9 V / 658 l/s</b>									
Surrounding	60	48	50	58	48	47	52	41	32
Supply air	85	57	62	81	73	71	80	72	65
Extract air	70	56	61	68	60	52	52	46	37
<b>8 V / 572 l/s</b>									
Surrounding	60	45	47	59	46	44	46	37	30
Supply air	81	54	63	78	72	69	73	68	60
Extract air	72	53	59	71	56	48	49	42	32
<b>7 V / 434 l/s</b>									
Surrounding	54	42	47	52	43	41	39	33	28
Supply air	76	51	67	72	66	67	69	64	56
Extract air	71	52	60	71	52	46	44	39	31
<b>6 V / 380 l/s</b>									
Surrounding	48	38	47	41	36	36	34	29	28
Supply air	71	49	64	65	60	63	63	58	51
Extract air	65	48	63	59	45	41	39	31	22
<b>5 V / 284 l/s</b>									
Surrounding	48	35	48	37	30	31	28	26	27
Supply air	65	48	59	60	54	56	56	51	43
Extract air	58	44	57	50	39	32	33	24	16

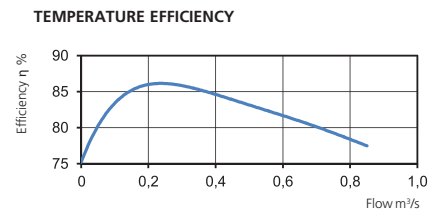
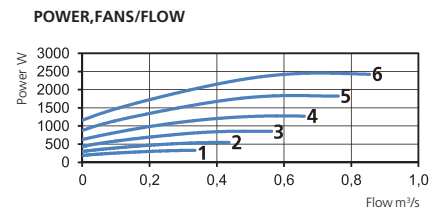
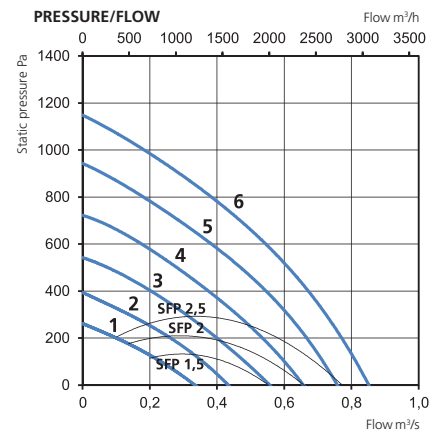

### CONTROL VOLTAGE

1	2	3	4	5	6
5V	6V	7V	8V	9V	10V

Pressure/airflow diagrams apply for both supply and extract air. Power and SFP apply for both of the fans together.

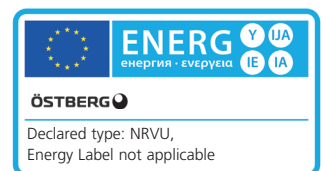

# ENERGY RECOVERY UNIT

## HERU®800 S EC

- Compact unit with side connections.
- Designed for supply and exhaust air ventilation with energy recovery.
- Suitable for installation in homes, offices and other premises where there are stringent requirements on the indoor environment.
- High temperature efficiency 86%, low energy consumption (SFP), low sound level, high operating reliability and provides clean indoor air.
- Unique design minimizes all thermal bridges.
- Can be ordered with integrated Siemens Climatix (CX) control equipment or without control equipment (ET). Comes prepared for Modbus communication via RS485 (accessory needed).
- Airflow is generated by two silent anti-vibration plug fans with EC motors and impellers with backward curved blades.

- The fans are connected with quick connectors and are very easy to remove for cleaning.
- Has a speed controlled rotating aluminum heat exchanger with adjustable hub and purge sector. The rotor can be removed for cleaning.
- Deep pleated filter ISO ePM1 65% as standard, for both exhaust and supply air. The filter is very easy to change.
- Available with integrated electric heater or heating coil.
- The water and electrical connections are positioned to facilitate practical and simple connection.
- The unit is made from aluminum-zinc-plated steel and insulated.
- For placement in both warm or cold environments.
- Available in either right-hand or left-hand design.
- Delivered with adjustable feet and Novibra mats.

### ACCESSORIES

- Filterkit ISO ePM1 65%
- Adjustable feet
- Novibra mat
- Control system
- Cooling coil
- Damper
- Flow meter
- U-pipe filter
- Valve actuator
- Shunt
- Water trap
- Silencer



### DIMENSIONS (mm)

#### RIGHT-HAND DESIGN

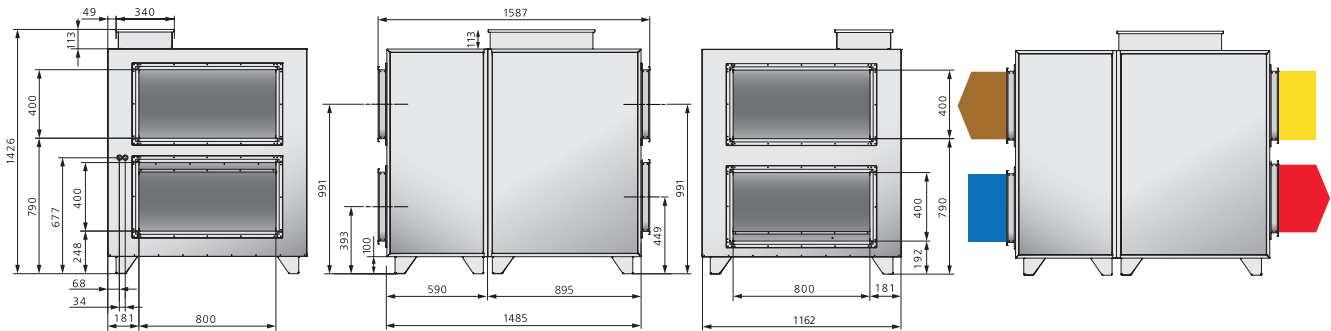

#### LEFT-HAND DESIGN

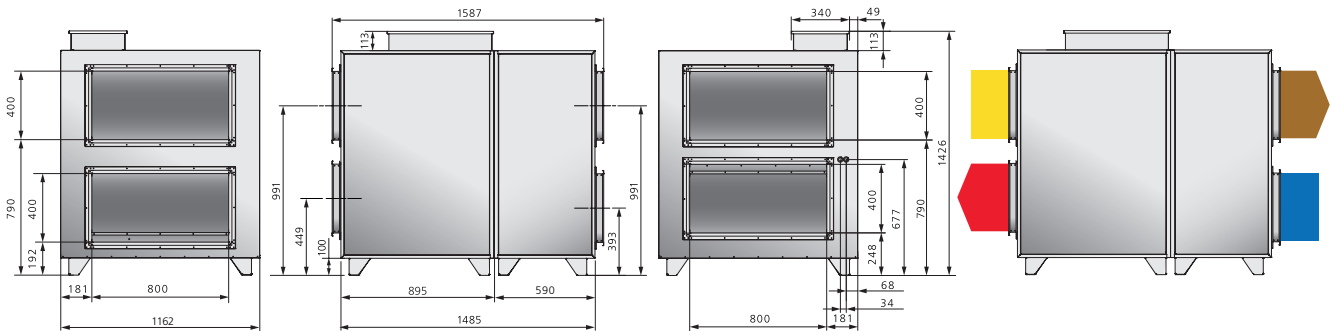

### CONNECTIONS

- Supply air
- Extract air
- Exhaust air
- Fresh air

Side connection

Capacity

EC = Fans with low-energy motors

400V = 3-Phase

**HERU®800S EC CX L W-400V**

CX = Control system Siemens Climatix  
ET = Without control system, routed to terminal block

W = Heater kit, water  
E = Electric heater

R = Right-hand design  
L = Left-hand design

Type	Art.no.
HERU®800 S EC CXLW 400V	997080128
HERU®800 S EC CXRW 400V	997080130
HERU®800 S EC CXLE 400V	997080132
HERU®800 S EC CXRE 400V	997080134



# ENERGY RECOVERY UNIT

## HERU®800 S EC

### TECHNICAL DATA

HERU®800 S EC	LW	LE
<b>Voltage</b>	Y 400	Y 400 V
<b>Frequency</b>	50	50 Hz
<b>Phase</b>	3	3 ~
<b>Current, 2 fans</b>	3.80	3.80 A
<b>Current, electric heater</b>	–	14.30 A
<b>Total current</b>	4.10	18.40 A
<b>Power, 2 fans</b>	2630	2630 W
<b>Power, electric heater</b>	–	9900 W
<b>Total power</b>	2790	12690 W
<b>Speed</b>	2510	2510 rpm
<b>Ingress Protection rating</b>	44	44 IP
<b>Sound pressure level, 3 m</b>	56	56 dB L <sub>PA</sub>
<b>Weight</b>	328	331 kg

### SOUND DATA (dB)

	Total (L <sub>wa</sub> )	63 Hz	125 Hz	250 Hz	500 Hz	1k Hz	2k Hz	4k Hz	8k Hz
<b>10 V / 960 l/s</b>									
Surrounding	63	55	59	60	49	48	49	49	35
Supply air	80	61	64	76	70	70	76	67	62
Extract air	71	58	60	68	65	60	53	46	37
<b>9.5 V / 900 l/s</b>									
Surrounding	62	52	58	60	47	47	47	47	34
Supply air	78	59	63	75	68	69	71	66	61
Extract air	69	56	58	66	63	58	54	45	36
<b>8.5 V / 770 l/s</b>									
Surrounding	62	50	56	60	44	43	43	44	31
Supply air	78	57	62	76	67	67	68	62	57
Extract air	71	54	57	70	60	54	49	42	32
<b>7 V / 660 l/s</b>									
Surrounding	58	45	57	51	38	38	37	37	29
Supply air	69	52	64	64	59	61	61	56	51
Extract air	62	50	59	58	53	45	44	35	24
<b>6 V / 530 l/s</b>									
Surrounding	58	41	58	44	34	35	34	33	29
Supply air	65	49	57	61	54	57	57	50	47
Extract air	58	47	55	52	48	40	39	30	19

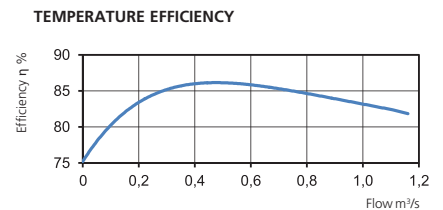
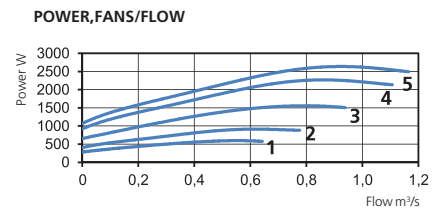
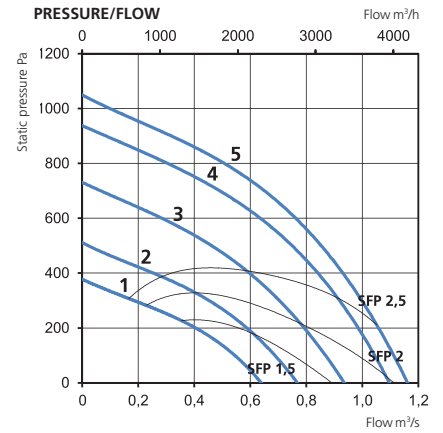

### CONTROL VOLTAGE

1	2	3	4	5
6V	7V	8.5V	9.5V	10V

Pressure/airflow diagrams apply for both supply and extract air. Power and SFP apply for both of the fans together.



# ENERGY RECOVERY UNIT

## HERU®1200 S EC

- Compact unit with side connections.
- Designed for supply and exhaust air ventilation with energy recovery.
- Suitable for installation in homes, offices and other premises where there are stringent requirements on the indoor environment.
- High temperature efficiency 86%, low energy consumption (SFP), low sound level, high operating reliability and provides clean indoor air.
- Unique design minimizes all thermal bridges.
- Can be ordered with integrated Siemens Climatix (CX) control equipment or without control equipment (ET). Comes prepared for Modbus communication via RS485 (accessory needed).
- Airflow is generated by two silent anti-vibration plug fans with EC motors and impellers with backward curved blades.

- The fans are connected with quick connectors and are very easy to remove for cleaning.
- Has a speed controlled rotating aluminum heat exchanger with adjustable hub and purge sector. The rotor can be removed for cleaning.
- Deep pleated filter ISO ePM1 65% as standard, for both exhaust and supply air. The filter is very easy to change.
- Available with integrated electric heater or heating coil.
- The water and electrical connections are positioned to facilitate practical and simple connection.
- The unit is made from aluminum-zinc-plated steel and insulated.
- For placement in both warm or cold environments.
- Available in either right-hand or left-hand design.
- Delivered with adjustable feet and Novibra mats.

### ACCESSORIES

- Filterkit ISO ePM1 65%
- Adjustable feet
- Novibra mat
- Control system
- Cooling coil
- Damper
- Flow meter
- U-pipe filter
- Valve actuator
- Shunt
- Water trap
- Silencer



### DIMENSIONS (mm)

#### RIGHT-HAND DESIGN

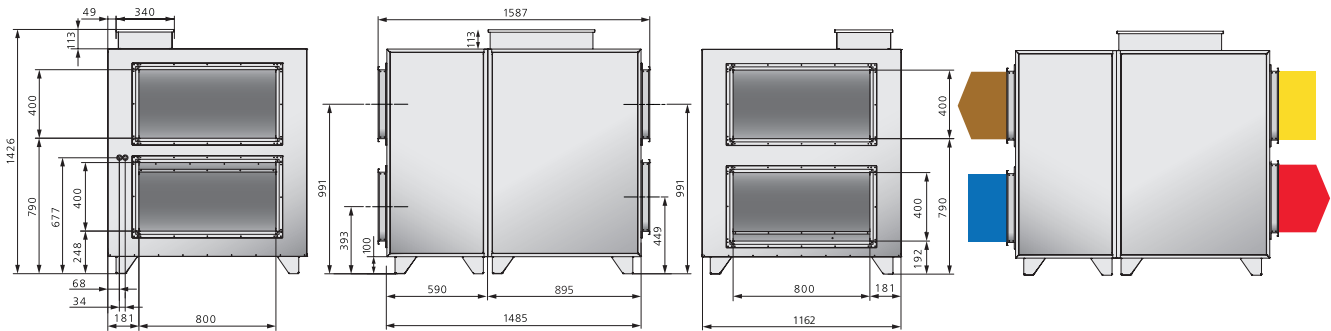

#### LEFT-HAND DESIGN

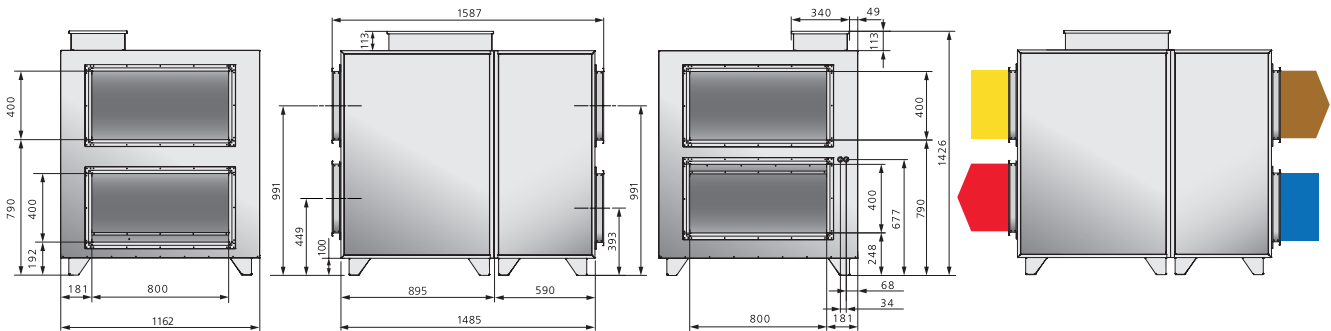

### CONNECTIONS

- Supply air
- Extract air
- Exhaust air
- Fresh air

### Side connection

Capacity

EC = Fans with low-energy motors

400V = 3-Phase

**HERU®1200S EC CX L W-400V**

CX = Control system Siemens Climatix  
ET = Without control system, routed to terminal block

W = Heater kit, water  
E = Electric heater

R = Right-hand design  
L = Left-hand design

Type	Art.no.
HERU®1200 S EC CXLW 400V	997080192
HERU®1200 S EC CXRW 400V	997080193
HERU®1200 S EC CXLE 400V	997080194
HERU®1200 S EC CXRE 400V	997080195



# ENERGY RECOVERY UNIT

## HERU®1200 S EC

### TECHNICAL DATA

HERU®1200 S EC	LW	LE
<b>Voltage</b>	Y 400	Y 400 V
<b>Frequency</b>	50	50 Hz
<b>Phase</b>	3	3 ~
<b>Current, 2 fans</b>	6.43	6.43 A
<b>Current, electric heater</b>	–	14.30 A
<b>Total current</b>	6.70	21.00 A
<b>Power, 2 fans</b>	4450	4450 W
<b>Power, electric heater</b>	–	9900 W
<b>Total power</b>	4620	14520 W
<b>Speed</b>	2970	2970 rpm
<b>Ingress Protection rating</b>	44	44 IP
<b>Sound pressure level, 3 m</b>	65	65 dB L <sub>PA</sub>
<b>Weight</b>	332	335 kg

### SOUND DATA (dB)

	Total (L <sub>wa</sub> )	63 Hz	125 Hz	250 Hz	500 Hz	1k Hz	2k Hz	4k Hz	8k Hz
<b>10 V / 1122 l/s</b>									
Surrounding	72	59	66	67	60	61	64	59	47
Supply air	92	68	73	85	83	87	86	80	73
Extract air	78	69	71	75	68	66	65	57	48
<b>9 V / 1020 l/s</b>									
Surrounding	70	58	65	66	58	59	61	56	41
Supply air	90	69	72	83	81	85	83	77	69
Extract air	76	66	69	73	65	64	61	54	45
<b>8 V / 909 l/s</b>									
Surrounding	67	55	63	63	54	55	57	52	37
Supply air	87	64	70	82	78	81	79	73	65
Extract air	73	63	67	70	61	60	58	50	41
<b>7 V / 797 l/s</b>									
Surrounding	65	53	61	61	50	51	52	46	32
Supply air	82	62	68	77	73	77	74	68	60
Extract air	71	61	65	67	58	56	54	46	36
<b>6 V / 657 l/s</b>									
Surrounding	61	50	58	57	46	46	47	41	28
Supply air	78	59	65	73	70	72	69	63	54
Extract air	69	59	62	67	53	51	49	40	30
<b>5 V / 525 l/s</b>									
Surrounding	56	47	54	50	40	40	41	34	26
Supply air	72	57	63	66	63	67	63	56	47
Extract air	63	55	60	57	46	45	42	33	21
<b>4 V / 381 l/s</b>									
Surrounding	50	43	48	43	33	33	33	28	26
Supply air	66	53	58	60	56	61	55	48	37
Extract air	57	52	53	50	38	38	34	24	12

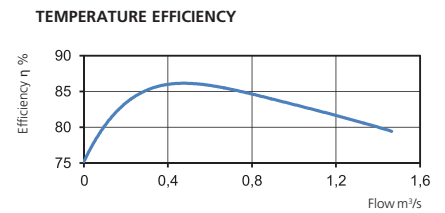
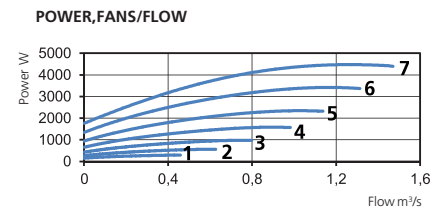
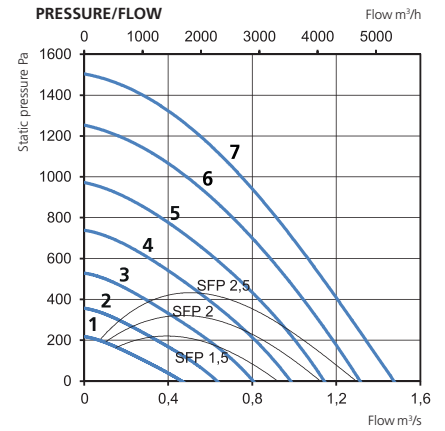

### CONTROL VOLTAGE

1	2	3	4	5	6	7
4V	5V	6V	7V	8V	9V	10V

Pressure/airflow diagrams apply for both supply and extract air. Power and SFP apply for both of the fans together.









## AIR HANDLING UNITS

## ENERGY RECOVERY UNITS

**HERU®K** ..... 12  
Kitchen unit with energy recovery for installation above the kitchen stove.  
HERU®K is available with EC motors.  
Airflows up to 325 m<sup>3</sup>/h (0.9 m<sup>3</sup>/s).

**HERU®T** ..... 14  
Unit with energy recovery and top connections.  
HERU®T is available with EC motors.  
Airflows up to 4300 m<sup>3</sup>/h (1.2 m<sup>3</sup>/s).

**HERU®LP**..... 32  
Low profile unit with energy recovery and side connections.  
HERU®LP is available with EC motors.  
Airflows up to 375 m<sup>3</sup>/h (0.10 m<sup>3</sup>/s).

**HERU®S** ..... 36  
Unit with energy recovery and side connections.  
HERU®S is available with EC motors.  
Airflows up to 4300 m<sup>3</sup>/h (1.2 m<sup>3</sup>/s).

## SUPPLY AIR UNITS

**SAU** ..... 54  
SAU supply air unit is designed to provide a comfortable indoor climate with controlled heating and clean, filtered air.  
SAU is available with AC and EC motors.  
Airflows up to 1000 m<sup>3</sup>/h (0.28 m<sup>3</sup>/s).

## ACCESSORIES

**HERU® ACCESSORIES**

**FILTER**..... 74  
**FEET, NOVIBRA MATS, FLOOR STAND** ..... 75  
**CEILING MOUNTING PLATE** ..... 75  
**COVER STRIP, FRONT COVER** ..... 75  
**OUTSIDE WALL HOOD**..... 76  
**CONTROL KIT** ..... 77  
**CONTROL SYSTEM SIEMENS CLIMATIX**..... 77  
**HEATERS** ..... 78  
**COOLING COILS**..... 78  
**RELAY PUMP CONTROL**..... 78  
**PRESSURE SENSOR KIT** ..... 79  
**DAMPERS**..... 79  
**FLOW METERS**..... 79  
**FILTER MONITORING**..... 79  
**SHUNT**..... 79  
**WATER TRAP** ..... 79

**SAU ACCESSORIES**

**FILTER**..... 80  
**FAN CONTROL UNITS**..... 80  
**CONTROL KIT**..... 80  
**REMOTE CONTROL**..... 81  
**ANTENNA**..... 81  
**CONTROL UNIT**..... 81

**OTHERS ACCESSORIES**

**SENSORS**..... 82  
**EXTENSION CABLE, ANTENNA** ..... 82  
**SILENCERS**..... 83  
**MOUNTING CLAMP** ..... 83  
**BACK DRAUGHT SHUTTERS** ..... 83  
**SAFETY GRILLE** ..... 83  
**LOUVRE SHUTTER** ..... 83

## SUPPLY AIR UNIT

# SAU 125 A1 AC

- Supply air unit with circular connections.
- Designed to provide a comfortable indoor climate with controlled heating and filtered, clean air.
- Low sound level, high operating reliability and provides clean indoor air.
- Comes complete with filter, fan and heater.
- Available with or without integrated pulses (with external set point adjuster) and duct sensor.
- Airflow is generated by a silent radial fan with AC motor, impeller with forward curved blades.
- The impeller is easy to clean thanks to its swing-out design.

- Integrated overheating protection for heaters and motor windings.
- The unit has enclosure class IP 44.
- Comes with filter ISO 16890 Coarse 65% as standard. The filter is very easy to change.
- Regulated with external control unit with two functions: Heater on/off and choice of two fan speeds. It is also possible to regulate externally using a Pulser.
- The unit is constructed of galvanized steel sheet and insulated with 50 mm mineral wool board with an outer layer of fibreglass weave for easy cleaning.
- For placement in warm or cold areas.

### ACCESSORIES

- Filter, ISO ePM1 65% and ISO 16890 Coarse 80%
- Fan control
- Silencer, LDC 125
- Mounting clamp, MK 125, simplifies connection to duct and absorbs vibrations.
- Back draught shutter, RSK 125
- Safety grille, BSR/BSV 125
- Louvre shutter, VK 125



### DIMENSIONS (mm)

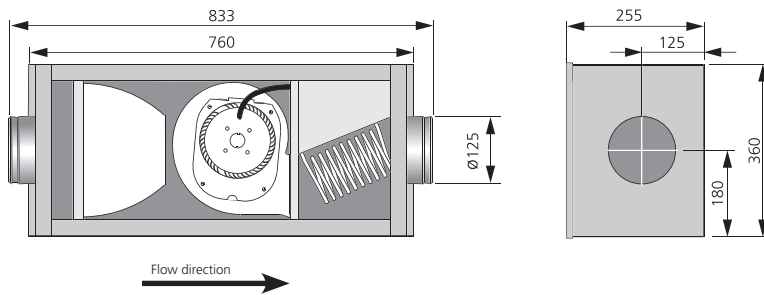

Type	Art.no.
SAU 125 A1, 1.0 kW	8000010
SAU 125 A1, 1.0 kW with Pulser	8000011





This product is not sold within the EU.

# SUPPLY AIR UNIT

## SAU 125 A1 AC

### TECHNICAL DATA

SAU 125 A1 AC	Without Pulser	With Pulser
<b>Voltage</b>	230	230 V
<b>Voltage, range</b>	220-240	220-240 V
<b>Frequency</b>	50	50 Hz
<b>Phase</b>	1	1 ~
<b>Total current</b>	4.50	4.50 A
<b>Power, fan</b>	41	41 W
<b>Power, electric heater</b>	1000	1000 W
<b>Total power</b>	1041	1041 W
<b>Speed</b>	1100	1100 rpm
<b>Capacitor</b>	3	3 $\mu$ F
<b>Max. temp of transported air</b>	50	50 $^{\circ}$ C
<b>Sound pressure level, 3 m</b>	38	38 dB $L_{PA}$
<b>Weight</b>	19.0	19.6 kg
<b>Wiring diagram</b>	4040037	4040038

### SOUND DATA (dB)

	Total ( $L_{wA}$ )	63 Hz	125 Hz	250 Hz	500 Hz	1k Hz	2k Hz	4k Hz	8k Hz
<b>230 V / 27 l/s</b>									
Surrounding	45	28	33	38	41	36	33	30	32
Outlet	59	49	54	50	51	53	48	42	36
Inlet	55	47	52	50	42	38	36	32	31

Above sound values measured with filter ISO ePM Coarse 65% (highest pressure/airflow).  
The filter only reduces pressure -> same sound values at same airflow regardless of filter class.

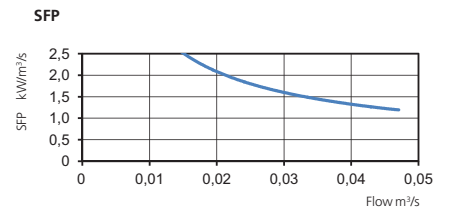
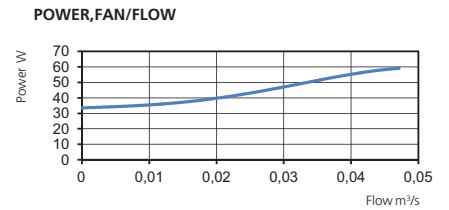
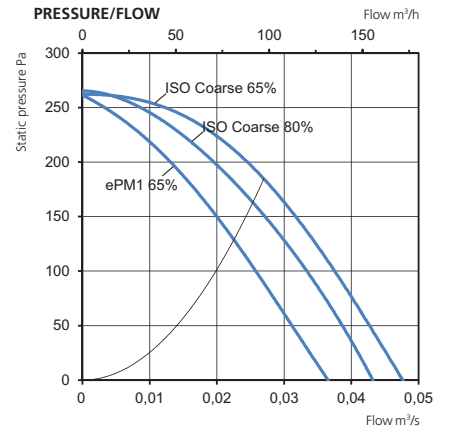

# SUPPLY AIR UNIT

## SAU 125 C1 AC

- Supply air unit with circular connections.
- Designed to provide a comfortable indoor climate with controlled heating and clean, filtered air.
- Low sound level, high operating reliability and provides clean indoor air.
- Comes complete with filter, fan and heater.
- Available with or without integrated pulses (with external setpoint adjuster) and duct sensor.
- The airflow is generated by a silent radial fan with AC motor, impeller with forward curved blades.
- The impeller is easy to clean thanks to its swing-out design.

- Integrated overheating protection for heaters and motor windings.
- The unit has enclosure class IP 44.
- Comes with filter ISO 16890 Coarse 65% as standard. The filter is very easy to change.
- Regulated with external control unit with two functions: Heater on/off and choice of two fan speeds.
- The unit is constructed of galvanized steel sheet and insulated with 50 mm mineral wool board with a outer layer of fibreglass weave for easy cleaning.
- For placement in warm or cold areas.

### ACCESSORIES

- Filter, ISO ePM1 65% and ISO 16890 Coarse 80%
- Fan control
- Silencer, LDC 125
- Mounting clamp, MK 125, simplifies connection to duct and absorbs vibrations.
- Back draught shutter, RSK 125
- Safety grille, BSR/BSV 125
- Louvre shutter, VK 125



### DIMENSIONS (mm)

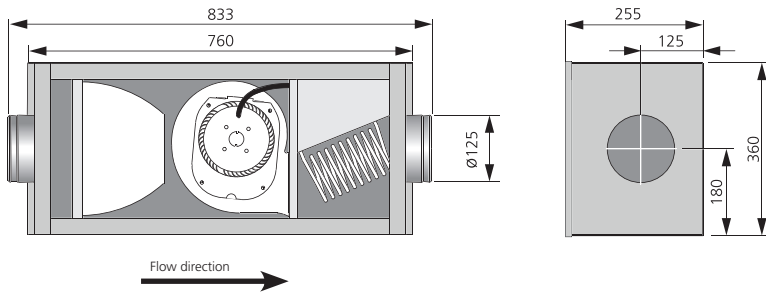

Type	Art.no.
SAU 125 C1, 2.0 kW	8000012
SAU 125 C1, 2.0 kW with Pulsar	8000013

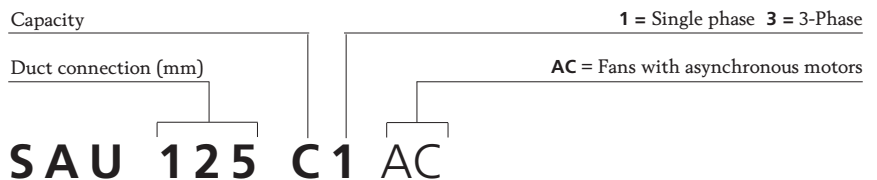





This product is not sold within the EU.

# SUPPLY AIR UNIT

## SAU 125 C1 AC

### TECHNICAL DATA

SAU 125 C1 AC	Without Pulser	With Pulser
<b>Voltage</b>	230	230 V
<b>Voltage, range</b>	220-240	220-240 V
<b>Frequency</b>	50	50 Hz
<b>Phase</b>	1	~
<b>Total current</b>	9.20	9.20 A
<b>Power, fan</b>	120	120 W
<b>Power, electric heater</b>	2000	2000 W
<b>Total power</b>	2110	2110 W
<b>Speed</b>	1850	1850 rpm
<b>Capacitor</b>	4	4 $\mu$ F
<b>Max. temp of transported air</b>	50	50 $^{\circ}$ C
<b>Sound pressure level, 3 m</b>	42	42 dB $L_{PA}$
<b>Weight</b>	17.8	18.5 kg
<b>Wiring diagram</b>	4040040	4040041

### SOUND DATA (dB)

	Total ( $L_{wA}$ )	63 Hz	125 Hz	250 Hz	500 Hz	1k Hz	2k Hz	4k Hz	8k Hz
<b>230 V / 63 l/s</b>									
Surrounding	49	28	38	44	45	39	36	32	32
Outlet	65	52	60	56	56	58	57	49	45
Inlet	60	50	56	56	48	43	42	40	30

Above sound values measured with filter ISO ePM Coarse 65% (highest pressure/airflow).  
The filter only reduces pressure -> same sound values at same airflow regardless of filter class.

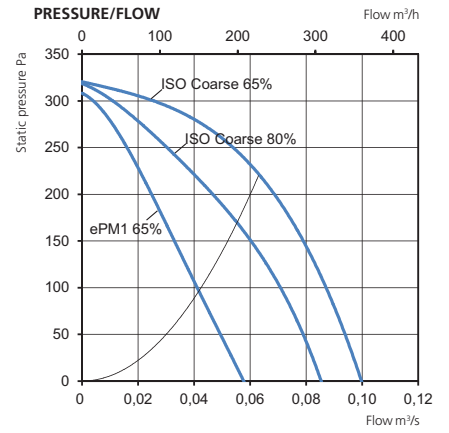

### POWER, FAN/FLOW

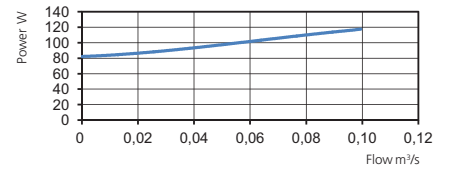

### SFP

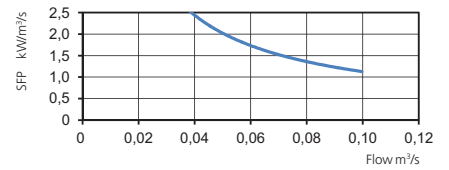

## SUPPLY AIR UNIT

# SAU 200 B1 AC

- Supply air unit with circular connections.
- Designed to provide a comfortable indoor climate with controlled heating and filtered, clean air.
- Low sound level, high operating reliability and provides clean indoor air.
- Comes complete with filter, fan and heater.
- Available with or without integrated pulses (with external setpoint adjuster) and duct sensor.
- Airflow is generated by a silent radial fans with AC motor, impeller with backward curved blades.
- The impeller is easy to clean thanks to its swing-out design.

- Integrated overheating protection for heaters and motor windings.
- The unit has enclosure class IP 44.
- Comes with filter ISO 16890 Coarse 65% as standard. The filter is very easy to change.
- Regulated with external control unit with two functions: Heater on/off and choice of two fan speeds.
- The unit is constructed of galvanized steel sheet and insulated with 50 mm mineral wool board with a outer layer of fibreglass weave for easy cleaning.
- For placement in warm or cold areas.

### ACCESSORIES

- Filter, ISO ePM1 65% and ISO 16890 Coarse 80%
- Fan control
- Silencer, LDC 200
- Mounting clamp, MK 200, simplifies connection to duct and absorbs vibrations.
- Back draught shutter, RSK 200
- Safety grille, BSR/BSV 200
- Louvre shutter, VK 200



### DIMENSIONS (mm)

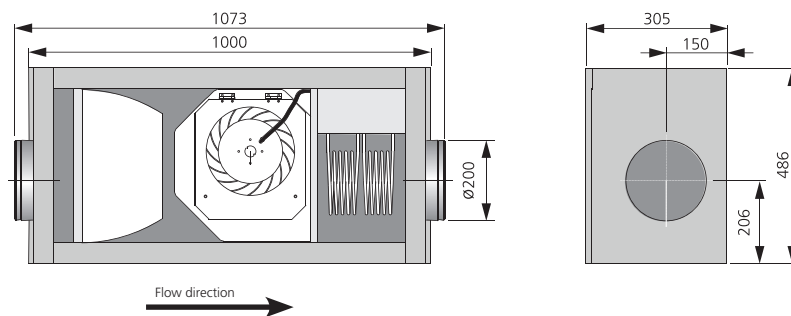

Type	Art.no.
SAU 200 B1, 2.0 kW	8000014
SAU 200 B1, 2.0 kW with Pulsar	8000015

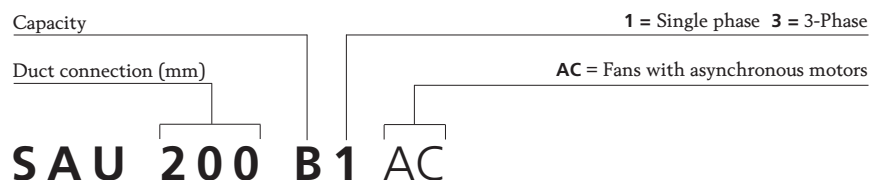



This product is not sold within the EU.

# SUPPLY AIR UNIT

## SAU 200 B1 AC

### TECHNICAL DATA

SAU 200 B1 AC	Without Pulsar	With Pulsar	
<b>Voltage</b>	230	230	V
<b>Voltage, range</b>	220-240	220-240	V
<b>Frequency</b>	50	50	Hz
<b>Phase</b>	1	1	~
<b>Total current</b>	9.20	9.20	A
<b>Power, fan</b>	105	105	W
<b>Power, electric heater</b>	2000	2000	W
<b>Total power</b>	2105	2105	W
<b>Speed</b>	2500	2500	rpm
<b>Capacitor</b>	4	4	µF
<b>Max. temp of transported air</b>	60	60	°C
<b>Sound pressure level, 3 m</b>	43	43	dB L <sub>PA</sub>
<b>Weight</b>	28.5	30.4	kg
<b>Wiring diagram</b>	4040040	4040041	

### SOUND DATA (dB)

	Total (L <sub>wA</sub> )	63 Hz	125 Hz	250 Hz	500 Hz	1k Hz	2k Hz	4k Hz	8k Hz
<b>230 V / 95 l/s</b>									
Surrounding	50	46	41	44	46	41	38	34	32
Outlet	69	51	55	62	66	63	58	51	39
Inlet	62	45	53	59	58	49	44	40	27

Above sound values measured with filter ISO ePM Coarse 65% (highest pressure/airflow).  
The filter only reduces pressure -> same sound values at same airflow regardless of filter class.

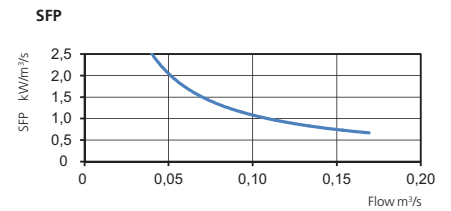
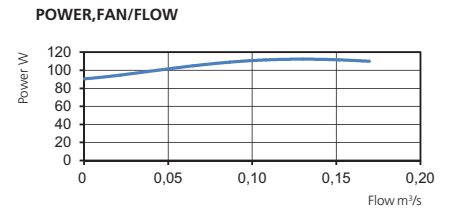
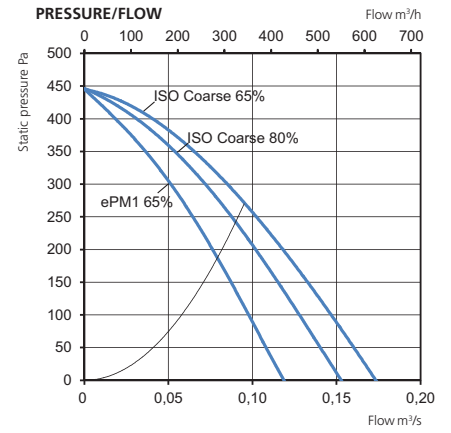

# SUPPLY AIR UNIT

## SAU 200 B3 AC

- Supply air unit with circular connections.
- Designed to provide a comfortable indoor climate with controlled heating and clean, filtered air.
- Low sound level, high operating reliability and provides clean indoor air.
- Comes complete with filter, fan and heater.
- Available with or without integrated pulses (with external setpoint adjuster) and duct sensor.
- Airflow is generated by a silent radial fan with AC motor, impeller with backward curved blades.
- The impeller is easy to clean thanks to its swing-out design.

- Integrated overheating protection for heaters and motor windings.
- The unit has enclosure class IP 44.
- Comes with filter ISO 16890 Coarse 65% as standard. The filter is very easy to change.
- Regulated with external control unit with two functions: Heater on/off and choice of two fan speeds.
- The unit is constructed of galvanized steel sheet and insulated with 50 mm mineral wool board with a outer layer of fibreglass weave for easy cleaning.
- For placement in warm or cold areas.

### ACCESSORIES

- Filter, ISO ePM1 65% and ISO 16890 Coarse 80%
- Fan control
- Silencer, LDC 200
- Mounting clamp, MK 200, simplifies connection to duct and absorbs vibrations.
- Back draught shutter, RSK 200
- Safety grille, BSR/BSV 200
- Louvre shutter, VK 200



### DIMENSIONS (mm)

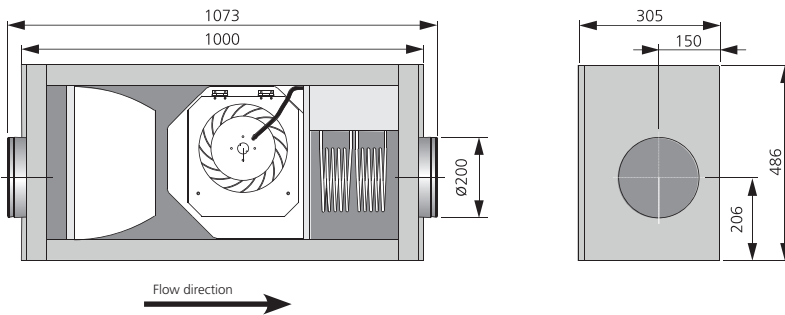

Type	Art.no.
SAU 200 B3, 5.0 kW	8000018
SAU 200 B3, 4.4 kW with Pulsar	8000019

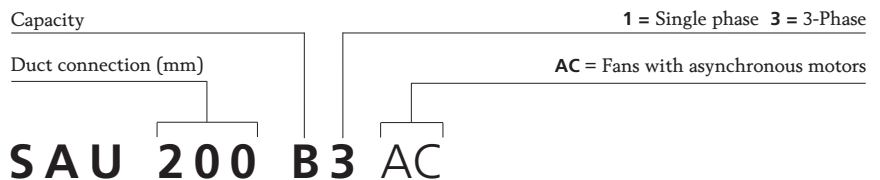



This product is not sold within the EU.

# SUPPLY AIR UNIT

## SAU 200 B3 AC

### TECHNICAL DATA

SAU 200 B3 AC	Without Pulser	With Pulser
<b>Voltage</b>	400	400 V
<b>Voltage, range</b>	380-415	380-415 V
<b>Frequency</b>	50	50 Hz
<b>Phase</b>	3	2 ~
<b>Total current</b>	11.60	11.60 A
<b>Power, fan</b>	105	105 W
<b>Power, electric heater</b>	5000	4400 W
<b>Total power</b>	5105	4505 W
<b>Speed</b>	2500	2500 rpm
<b>Capacitor</b>	4	4 µF
<b>Max. temp of transported air</b>	50	50 °C
<b>Sound pressure level, 3 m</b>	43	43 dB L <sub>PA</sub>
<b>Weight</b>	30.0	31.3 kg
<b>Wiring diagram</b>	4040043	4040044

### SOUND DATA (dB)

	Total (L <sub>WA</sub> )	63 Hz	125 Hz	250 Hz	500 Hz	1k Hz	2k Hz	4k Hz	8k Hz
<b>230 V / 95 l/s</b>									
Surrounding	50	46	41	44	46	41	38	34	32
Outlet	69	51	55	62	66	63	58	51	39
Inlet	62	45	53	59	58	49	44	40	27

Above sound values measured with filter ISO ePM Coarse 65% (highest pressure/airflow).  
The filter only reduces pressure -> same sound values at same airflow regardless of filter class.

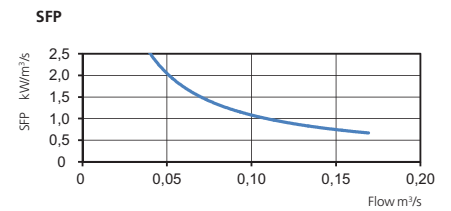
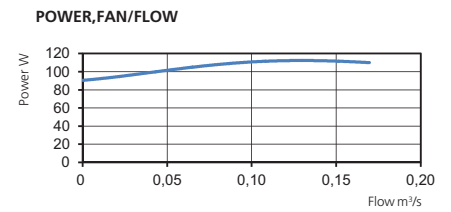
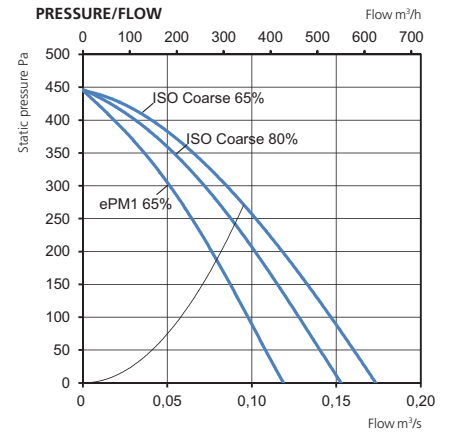



# SUPPLY AIR UNIT

## SAU 200 C3 Erp AC

- Supply air unit with circular connections.
- Designed to provide a comfortable indoor climate with controlled heating and filtered, clean air.
- Low sound level, high operating reliability and provides clean indoor air.
- Comes complete with filter, fan and heater.
- Available with or without integrated pulses (with external setpoint adjuster) and duct sensor.
- Airflow is generated by a silent radial fan with AC motor, impeller with backward curved blades.
- The impeller is easy to clean thanks to its swing-out design.

- Integrated overheating protection for heaters and motor windings.
- The unit has enclosure class IP 44.
- Comes with filter ISO 16890 Coarse 65% as standard. The filter is very easy to change.
- Regulated with external control unit with two functions: Heater on/off and choice of two fan speeds.
- The unit is constructed of galvanized steel sheet and insulated with 50 mm mineral wool board with a outer layer of fibreglass weave for easy cleaning.
- For placement in warm or cold areas.

### ACCESSORIES

- Filter, ISO ePM1 65% and ISO 16890 Coarse 80%
- Fan control
- Silencer, LDC 200
- Mounting clamp, MK 200, simplifies connection to duct and absorbs vibrations.
- Back draught shutter, RSK 200
- Safety grille, BSR/BSV 200
- Louvre shutter, VK 200



### DIMENSIONS (mm)

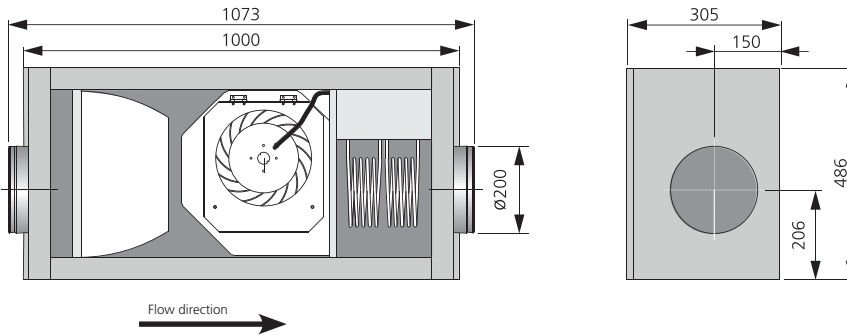

Type	Art.no.
SAU 200 C3, 5.0 kW	8000024
SAU 200 C3, 4.4 kW with Pulsar	8000025

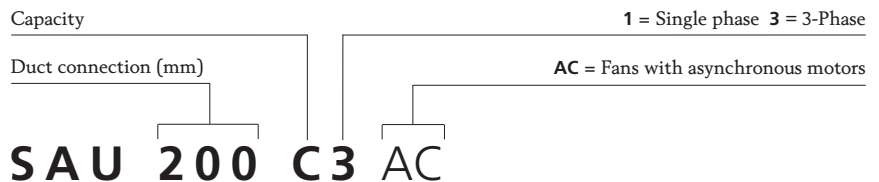



This product is not sold within the EU.

# SUPPLY AIR UNIT

## SAU 200 C3 Erp AC

### TECHNICAL DATA

SAU 200 C3 Erp AC	Without Pulser	With Pulser
<b>Voltage</b>	400	400 V
<b>Voltage, range</b>	380-415	380-415 V
<b>Frequency</b>	50	50 Hz
<b>Phase</b>	3	2 ~
<b>Total current</b>	13.00	11.70 A
<b>Power, fan</b>	150	150 W
<b>Power, electric heater</b>	5000	4400 W
<b>Total power</b>	5150	4550 W
<b>Speed</b>	2740	2740 rpm
<b>Capacitor</b>	5	5 $\mu$ F
<b>Max. temp of transported air</b>	40	40 $^{\circ}$ C
<b>Sound pressure level, 3 m</b>	45	45 dB $L_{PA}$
<b>Weight</b>	31.3	32.0 kg
<b>Wiring diagram</b>	4040043	4040044

### SOUND DATA (dB)

	Total ( $L_{wA}$ )	63 Hz	125 Hz	250 Hz	500 Hz	1k Hz	2k Hz	4k Hz	8k Hz
<b>230 V / 159 l/s</b>									
Surrounding	52	37	40	51	45	38	34	31	28
Outlet	71	56	59	65	66	62	61	61	52
Inlet	62	56	58	57	52	42	40	43	31

Above sound values measured with filter ISO ePM Coarse 65% (highest pressure/airflow).  
The filter only reduces pressure -> same sound values at same airflow regardless of filter class.

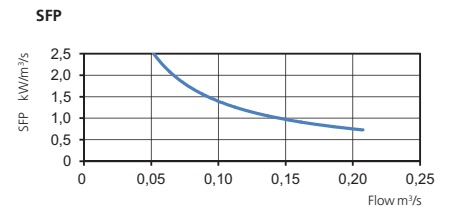
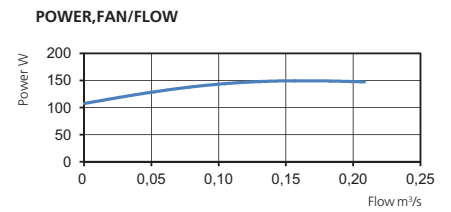
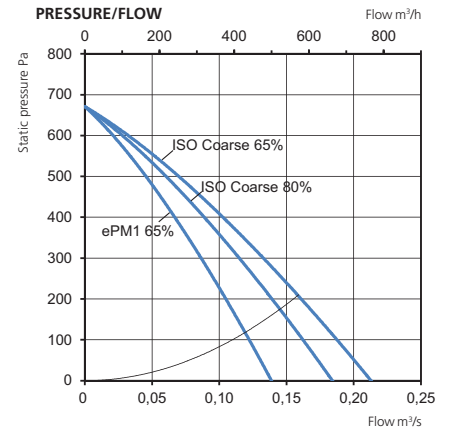

# SUPPLY AIR UNIT

## SAU 250 E AC

- Supply air unit with circular connections.
- Designed to provide a comfortable indoor climate with controlled heating and clean, filtered air.
- Low sound level, high operating reliability and provides clean indoor air.
- Comes complete with filter, fan and heater.
- SAU 250 with a water battery is operated using a 3-way valve and control equipment.
- Available with or without integrated pulses (with external setpoint adjuster) and duct sensor.
- Airflow is generated by a silent radial fan with AC motor, impeller with backward curved blades.

- The impeller is easy to clean thanks to its swing-out design.
- Integrated overheating protection for heater and motor windings.
- Comes with filter ISO 16890 Coarse 65% as standard. The filter is very easy to change.
- Regulated with external control unit with two functions: Heater on/off and choice of two fan speeds.
- The unit is constructed of galvanized steel sheet and insulated with 50 mm mineral wool board with a outer layer of fibreglass weave for easy cleaning.
- For placement in warm or cold areas.

### ACCESSORIES

- Filter, ISO ePM1 65% and ISO 16890 Coarse 80%
- Control Kit
- Silencer, LDC 250
- Mounting clamp, MK 250, simplifies connection to duct and absorbs vibrations.
- Back draught shutter, RSK 250
- Safety grille, BSR/BSV 250
- Louvre shutter, VK 250



### DIMENSIONS (mm)

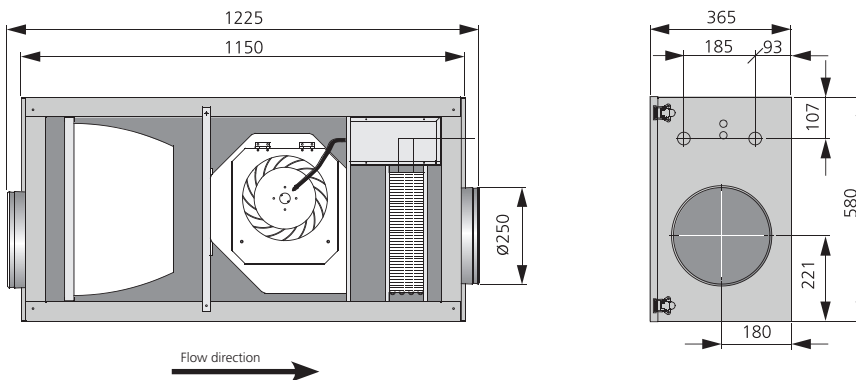

Type	Art.no.
SAU 250 E	800004





This product is not sold within the EU.

## SUPPLY AIR UNIT

### SAU 250 E AC

#### TECHNICAL DATA

SAU 250 E AC	
Voltage	230 V
Voltage, range	220-240 V
Frequency	50 Hz
Phase	1 ~
Total current	0.80 A
Power, fan	183 W
Power, electric heater	- W
Total power	183 W
Speed	2420 rpm
Capacitor	5 µF
Max. temp of transported air	40 °C
Sound pressure level, 3 m	45 dB L <sub>PA</sub>
Weight	50.0 kg
Wiring diagram	4040058

#### TECHNICAL DATA with water battery

Airflow	250 l/s and 45°C DT	200 l/s and 50°C DT	150 l/s and 55°C DT	
Power	14.7	12.7	10.3	kW
Water temperature	60/40	60/40	60/40	°C
Pressure dop	11.2	8.5	5.9	kPa
Flow	0.18	0.15	0.12	l/s
Connection	18	18	18	Ø mm

#### SOUND DATA (dB)

	Total (L <sub>WA</sub> )	63 Hz	125 Hz	250 Hz	500 Hz	1k Hz	2k Hz	4k Hz	8k Hz
<b>230 V / 177 l/s</b>									
Surrounding	52	36	40	51	41	32	31	32	29
Outlet	71	56	56	68	62	60	61	56	44
Inlet	60	57	50	55	43	39	36	32	25
<b>165 V / 151 l/s</b>									
Surrounding	54	32	36	53	37	29	27	28	28
Outlet	66	51	53	62	59	54	57	49	38
Inlet	54	48	48	50	38	33	31	26	19
<b>135 V / 117 l/s</b>									
Surrounding	47	31	33	47	32	26	25	27	28
Outlet	63	47	49	61	55	48	51	40	30
Inlet	51	44	42	49	35	27	26	19	13
<b>110 V / 86 l/s</b>									
Surrounding	38	24	35	32	26	25	24	26	28
Outlet	52	41	49	46	43	41	38	27	19
Inlet	44	38	41	36	25	21	17	14	10
<b>80 V / 63 l/s</b>									
Surrounding	34	25	26	24	20	25	24	26	28
Outlet	43	36	39	36	33	28	23	15	11
Inlet	35	31	30	27	15	11	14	13	9

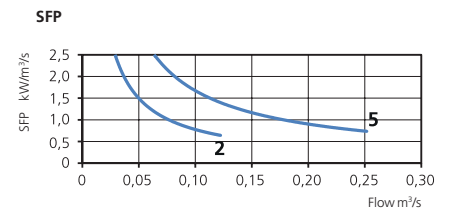
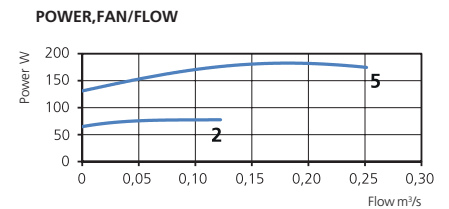
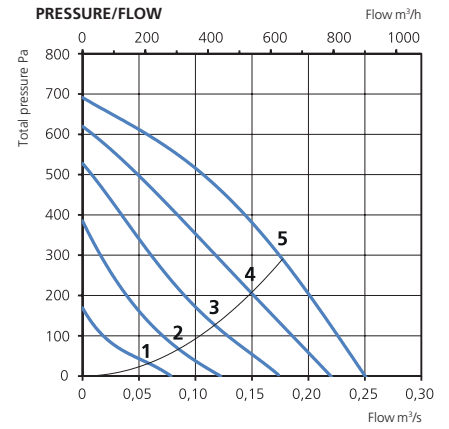

#### TRANSFORMER STEPS

1	2	3	4	5
80V	110V	135V	165V	230V

# SUPPLY AIR UNIT

## SAU 125 C1 EC

- An insulated supply air unit with circular connections.
- Designed to provide a comfortable indoor climate with controlled heating and filtered, clean air.
- The unit has an external control unit for operating and to preset the required temperature as well as monitor the unit's status.
- Low sound level, high operating reliability and provides clean indoor air.
- Comes with Modbus communication via RS485 as standard.
- Comes complete with filter, fan, duct sensor and electrical heater as standard.

- Airflow is generated by a silent radial fan with EC motor, impeller with backward curved blades.
- The fan house and impeller is easy to clean.
- Comes with filter ISO ePM1 50% as standard. The filter is very easy to change.
- Duct connections are equipped with rubber seals.
- The unit is constructed from galvanized steel sheet and insulated with an easy to clean 30 mm fiberglass.
- For placement in warm or cold areas.

### ACCESSORIES

- Filter ISO ePM2.5 60%
- Remote control
- Antenna
- Control unit
- Carbon dioxide sensor CO2
- Humidity sensor RH
- Room sensor Temp
- Duct sensor
- Extension cable, antenna
- Silencer LDC 125
- Mounting clamp MK 125, simplifies connection to duct and absorbs vibrations.
- Back draught shutter RSK 125
- Safety grille BSR/BSV 125
- Louvre shutters VK 125



### DIMENSIONS (mm)

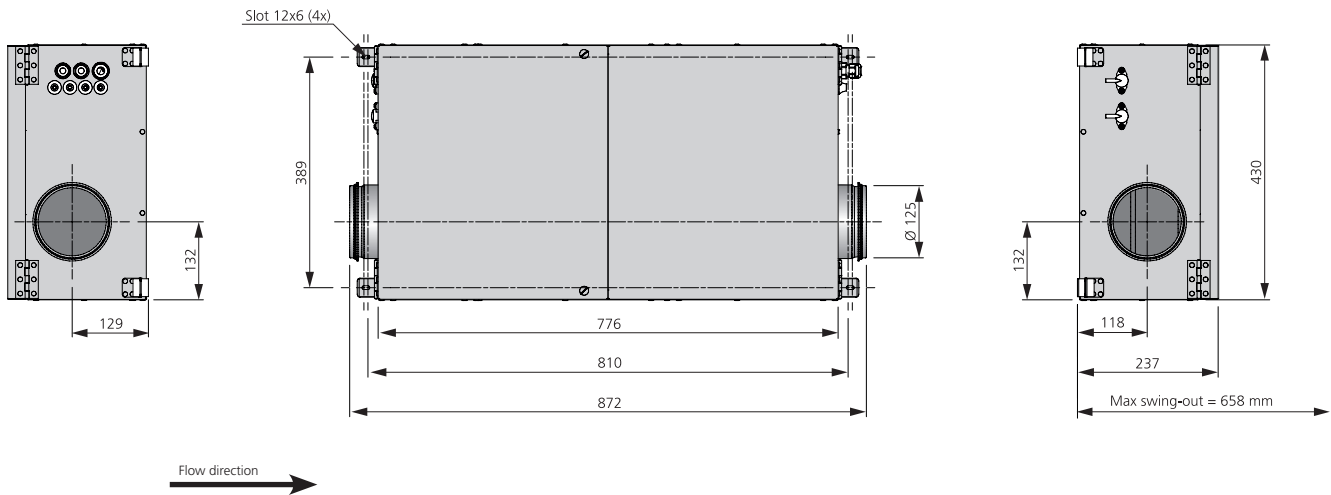

Type	Art.no.
SAU 125 C1 EC	8000063

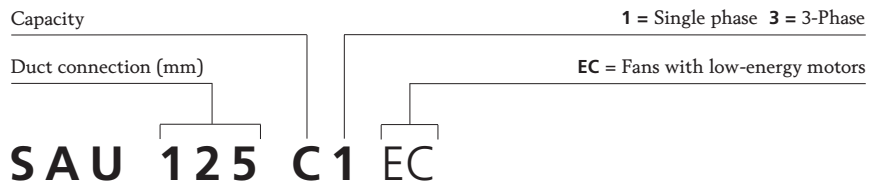





# SUPPLY AIR UNIT

## SAU 125 C1 EC

### TECHNICAL DATA

SAU 125 C1 EC	
Voltage	230 V
Voltage, range	220-240 V
Frequency	50 Hz
Phase	1 ~
Total current	9.60 A
Power, fan	101 W
Power, electric heater	2000 W
Total power	2110 W
Speed	3540 rpm
Capacitor	5 μF
Max. temp of transported air	60 °C
Sound pressure level, 3 m	45 dB L <sub>PA</sub>
Weight	20.4 kg
Wiring diagram	4040206

### SOUND DATA (dB)

	Total (L <sub>WA</sub> )	63 Hz	125 Hz	250 Hz	500 Hz	1k Hz	2k Hz	4k Hz	8k Hz
<b>10 V / 75 l/s</b>									
Surrounding	52	32	45	50	46	37	34	34	30
Outlet	73	57	61	64	67	63	67	60	52
Inlet	61	51	54	57	51	43	48	44	33
<b>9 V / 70 l/s</b>									
Surrounding	51	29	43	48	45	36	33	32	29
Outlet	72	56	60	63	67	62	66	58	50
Inlet	60	51	54	56	50	41	47	42	31
<b>8 V / 64 l/s</b>									
Surrounding	49	30	42	46	40	33	31	30	29
Outlet	69	55	59	62	61	59	64	55	46
Inlet	58	50	53	54	46	38	44	39	27
<b>7 V / 55 l/s</b>									
Surrounding	47	27	40	44	38	30	29	28	28
Outlet	66	54	58	60	57	55	61	52	42
Inlet	55	47	51	51	42	36	41	36	23
<b>6 V / 47 l/s</b>									
Surrounding	44	22	37	41	34	28	26	27	28
Outlet	63	51	54	58	53	51	57	47	36
Inlet	53	46	49	48	39	32	37	32	19
<b>5 V / 40 l/s</b>									
Surrounding	41	20	33	38	31	26	24	27	28
Outlet	59	49	51	56	49	47	52	41	29
Inlet	51	44	45	49	35	28	33	26	13
<b>3 V / 24 l/s</b>									
Surrounding	34	16	26	27	23	24	23	27	28
Outlet	48	43	43	39	37	36	39	25	13
Inlet	42	38	37	33	25	17	20	13	9

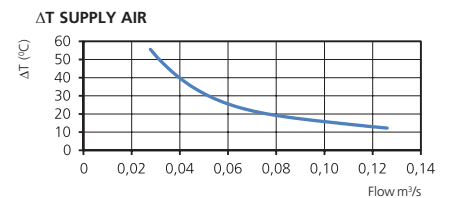
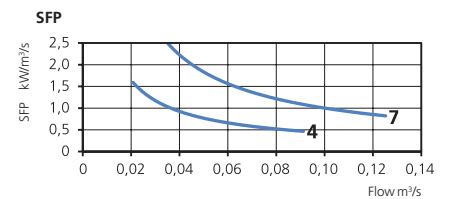
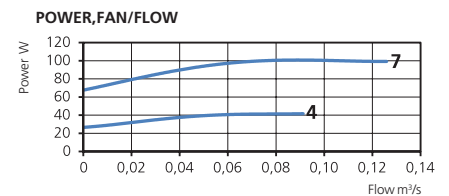
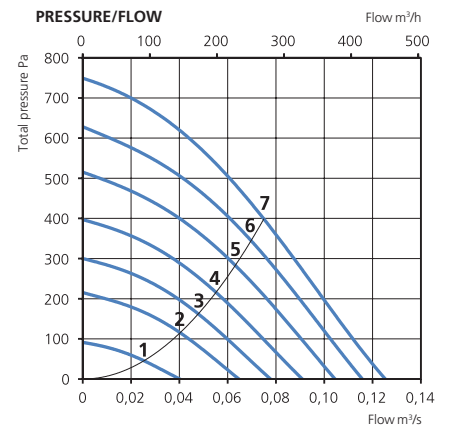

### TRANSFORMER STEPS

1	2	3	4	5	6	7
3V	5V	6V	7V	8V	9V	10V

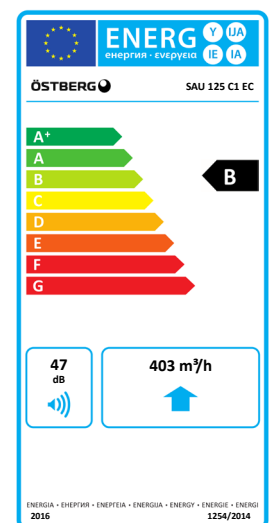

# SUPPLY AIR UNIT

## SAU 200 B3 EC

- An insulated supply air unit with circular connections.
- Designed to provide a comfortable indoor climate with controlled heating and filtered, clean air.
- The unit has an external control unit for operating and to preset the required temperature as well as monitor the unit's status.
- Low sound level, high operating reliability and provides clean indoor air.
- Comes with Modbus communication via RS485 as standard.
- Comes complete with filter, fan, duct sensor and electrical heater as standard.

- Airflow is generated by a silent radial fan with EC motor, impeller with backward curved blades.
- The fan house and impeller is easy to clean.
- Comes with filter ISO ePM1 50% as standard. The filter is very easy to change.
- Duct connections are equipped with rubber seals.
- The unit is constructed from galvanized steel sheet and insulated with an easy to clean 30 mm fiberglass.
- For placement in warm or cold areas.

### ACCESSORIES

- Filter ISO ePM2.5 60%
- Remote control
- Antenna
- Control unit
- Carbon dioxide sensor CO2
- Humidity sensor RH
- Room sensor Temp
- Duct sensor
- Extension cable, antenna
- Silencer LDC 200
- Mounting clamp MK 200, simplifies connection to duct and absorbs vibrations.
- Back draught shutter RSK 200
- Safety grille BSR/BSV 200
- Louvre shutters VK 200



### DIMENSIONS (mm)

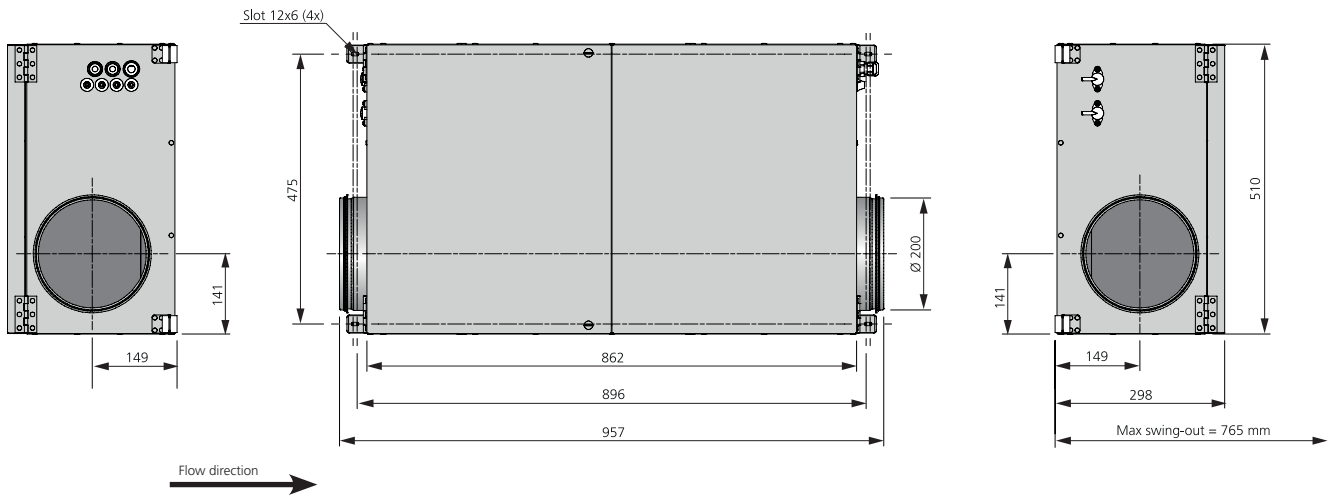

Type	Art.no.
SAU 200 B3 EC	8000065

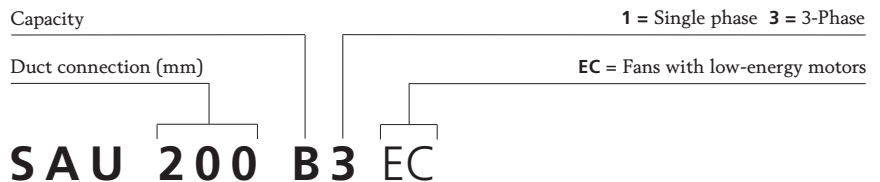



# SUPPLY AIR UNIT

## SAU 200 B3 EC

### TECHNICAL DATA

SAU 200 B3 EC	
Voltage	400 V
Voltage, range	220-240 V
Frequency	50 Hz
Phase	3 ~
Total current	13.5 A
Power, fans	0.95 W
Power, electric heater	5000 W
Total power	5130 W
Speed	2860 rpm
Capacitor	- μF
Max. temp of transported air	60 °C
Sound pressure level, 3 m	46 dB L <sub>PA</sub>
Weight	26.0 kg
Wiring diagram	4040207

### SOUND DATA (dB)

	Total (L <sub>WA</sub> )	63 Hz	125 Hz	250 Hz	500 Hz	1k Hz	2k Hz	4k Hz	8k Hz
<b>10 V / 119 l/s</b>									
Surrounding	53	33	42	52	45	35	33	30	28
Outlet	73	59	59	69	66	62	60	59	53
Inlet	63	52	55	61	52	44	42	42	32
<b>9 V / 109 l/s</b>									
Surrounding	52	30	40	51	43	34	31	29	27
Outlet	70	56	58	67	65	60	58	57	50
Inlet	61	50	53	60	50	42	41	40	30
<b>8 V / 97 l/s</b>									
Surrounding	52	27	39	51	41	31	28	27	27
Outlet	70	53	57	68	62	58	56	54	46
Inlet	60	47	52	59	47	40	38	37	26
<b>7 V / 87 l/s</b>									
Surrounding	49	26	38	48	39	29	26	26	27
Outlet	69	51	55	68	60	55	53	51	42
Inlet	61	45	48	60	44	36	35	33	20
<b>6 V / 76 l/s</b>									
Surrounding	46	25	35	45	35	27	24	25	27
Outlet	66	49	54	65	56	51	50	46	36
Inlet	57	43	46	56	41	34	32	30	16
<b>5 V / 42 l/s</b>									
Surrounding	41	23	31	39	31	26	22	25	27
Outlet	61	48	51	60	51	47	46	40	28
Inlet	55	41	44	54	38	30	28	24	11
<b>3 V / 24 l/s</b>									
Surrounding	34	19	27	27	23	24	21	25	27
Outlet	49	43	42	43	41	37	32	22	11
Inlet	42	37	35	37	28	20	15	10	8

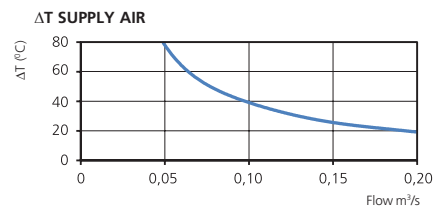
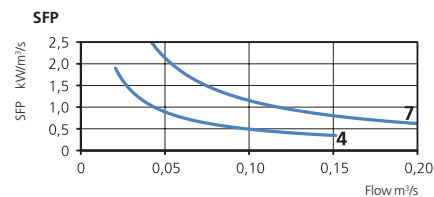
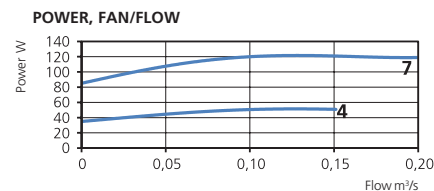
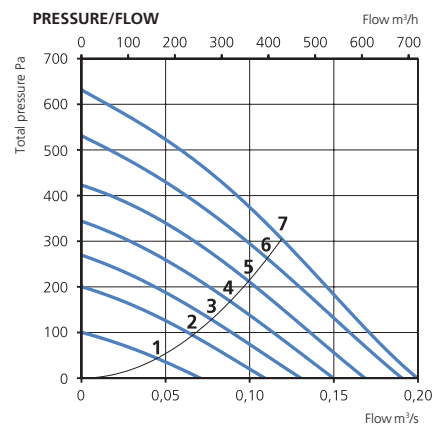

### TRANSFORMER STEPS

1	2	3	4	5	6	7
3V	5V	6V	7V	8V	9V	10V

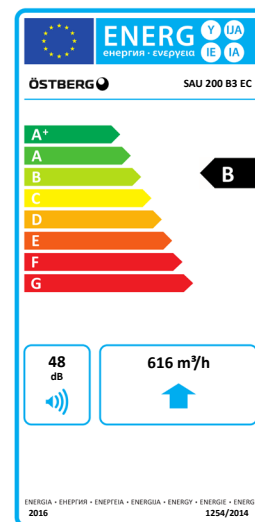

# SUPPLY AIR UNIT

## SAU 250 B3 EC

- An insulated supply air unit with circular connections.
- Designed to provide a comfortable indoor climate with controlled heating and filtered, clean air.
- The unit has an external control unit for operating and to preset the required temperature as well as monitor the unit's status.
- Low sound level, high operating reliability and provides clean indoor air.
- Comes with Modbus communication via RS485 as standard.
- Comes complete with filter, fan, duct sensor and electrical heater as standard.

- Airflow is generated by a silent radial fan with EC motor, impeller with backward curved blades.
- The fan house and impeller is easy to clean.
- Comes with filter ISO ePM1 50% as standard. The filter is very easy to change.
- Duct connections are equipped with rubber seals.
- The unit is constructed from galvanized steel sheet and insulated with an easy to clean 30 mm fiberglass.
- For placement in warm or cold areas.

### ACCESSORIES

- Filter ISO ePM2.5 60%
- Remote control
- Antenna
- Control unit
- Room sensor Temp
- Carbon dioxide sensor CO2
- Humidity sensor RH
- Duct sensor
- Extension cable, antenna
- Silencer LDC 250
- Mounting clamp MK 250, simplifies connection to duct and absorbs vibrations.
- Back draught shutter RSK 250
- Safety grille BSR/BSV 250
- Louvre shutters VK 250



### DIMENSIONS (mm)

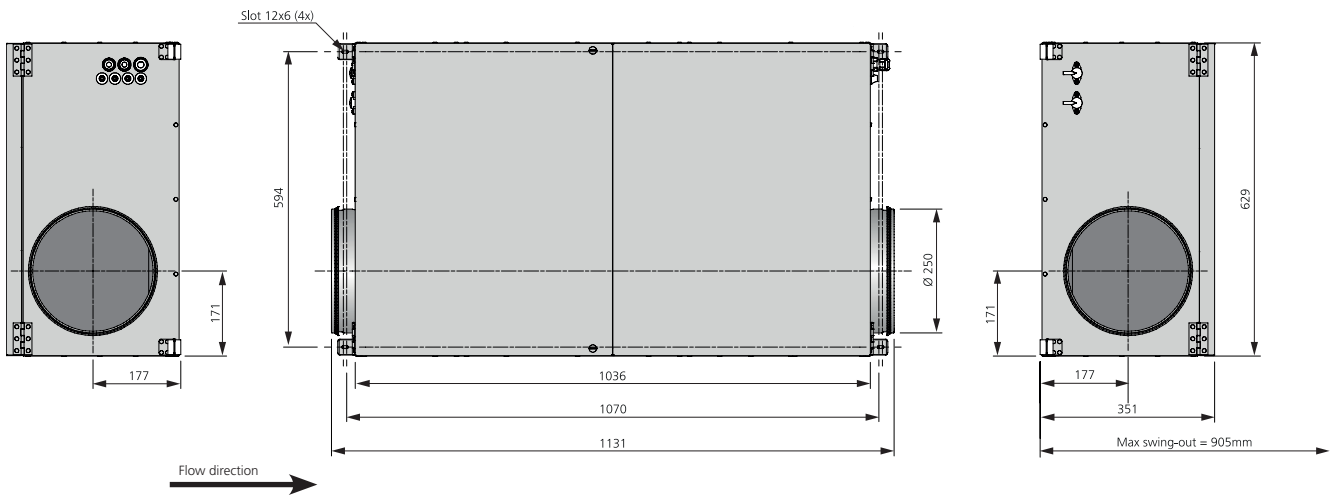

Capacity

1 = Single phase 3 = 3-Phase

Duct connection (mm)

EC = Fans with low-energy motors

Type	Art.no.
SAU 250 B3 EC	8000067

SAU 250 B3 EC

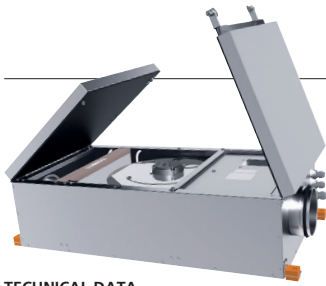

# SUPPLY AIR UNIT

## SAU 250 B3 EC

### TECHNICAL DATA

SAU 250 B3 EC	
Voltage	400 V
Voltage, range	220-240 V
Frequency	50 Hz
Phase	3 ~
Total current	13.9 A
Power, fans	166 W
Power, electric heater	5000 W
Total power	5180 W
Speed	2970 rpm
Capacitor	- μF
Max. temp of transported air	45 °C
Sound pressure level, 3 m	41 dB L <sub>PA</sub>
Weight	36.1 kg
Wiring diagram	4040207

### SOUND DATA (dB)

	Total (L <sub>wa</sub> )	63 Hz	125 Hz	250 Hz	500 Hz	1k Hz	2k Hz	4k Hz	8k Hz
<b>10 V / 161 l/s</b>									
Surrounding	49	40	36	48	40	35	32	32	29
Outlet	70	63	56	66	61	62	58	57	50
Inlet	58	53	53	54	43	41	40	38	31
<b>8 V / 142 l/s</b>									
Surrounding	47	30	33	46	37	32	30	30	27
Outlet	67	51	52	64	60	59	54	54	46
Inlet	54	48	45	52	38	38	36	36	27
<b>7 V / 132 l/s</b>									
Surrounding	46	27	31	45	35	30	28	27	26
Outlet	65	49	50	62	58	56	52	52	42
Inlet	54	45	43	52	35	35	34	34	23
<b>6 V / 115 l/s</b>									
Surrounding	46	30	31	45	34	29	26	26	26
Outlet	64	45	48	62	55	52	50	48	36
Inlet	53	42	41	52	34	32	32	30	18
<b>5 V / 98 l/s</b>									
Surrounding	40	22	27	39	30	26	24	25	26
Outlet	58	42	45	56	49	48	46	41	29
Inlet	53	39	37	53	31	28	29	26	14
<b>4 V / 79 l/s</b>									
Surrounding	34	20	27	28	26	25	22	25	26
Outlet	51	40	45	46	43	42	40	32	20
Inlet	43	36	40	37	25	22	23	19	12
<b>2 V / 52 l/s</b>									
Surrounding	32	17	20	23	22	24	22	25	26
Outlet	42	30	37	37	33	30	24	22	14
Inlet	35	26	32	30	17	13	16	15	12

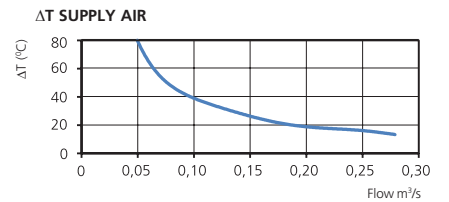
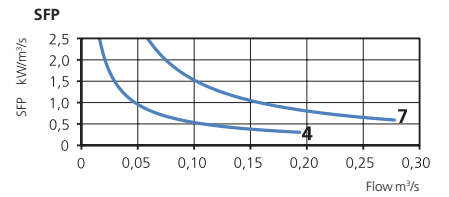
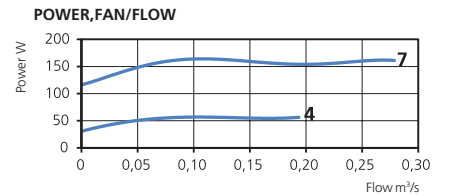
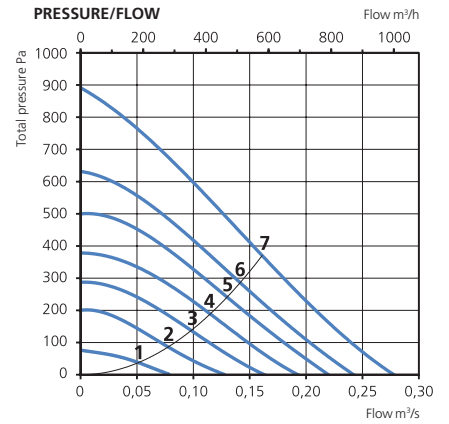

### TRANSFORMER STEPS

1	2	3	4	5	6	7
2V	4V	5V	6V	7V	8V	10V

**ENERG**  
енергия - енергия

**ÖSTBERG** SAU 250 B3 EC

Energy efficiency class: **B**

Sound power level: **46 dB**

Flow rate: **864 m<sup>3</sup>/h**

ENERGIA - ENERGIA - ENERGIJA - ENERGIJA - ENERGIJA - ENERGIJA - ENERGIJA - ENERGIJA - ENERGIJA - ENERGIJA  
2016 1254/2014







## AIR HANDLING UNITS

### ENERGY RECOVERY UNITS

<b>HERU®K</b> .....	12
Kitchen unit with energy recovery for installation above the kitchen stove. HERU®K is available with EC motors. Airflows up to 325 m <sup>3</sup> /h (0.9 m <sup>3</sup> /s).	
<b>HERU®T</b> .....	14
Unit with energy recovery and top connections. HERU®T is available with EC motors. Airflows up to 4300 m <sup>3</sup> /h (1.2 m <sup>3</sup> /s).	
<b>HERU®LP</b> .....	32
Low profile unit with energy recovery and side connections. HERU®LP is available with EC motors. Airflows up to 375 m <sup>3</sup> /h (0.10 m <sup>3</sup> /s).	
<b>HERU®S</b> .....	36
Unit with energy recovery and side connections. HERU®S is available with EC motors. Airflows up to 4300 m <sup>3</sup> /h (1.2 m <sup>3</sup> /s).	

### SUPPLY AIR UNITS

<b>SAU</b> .....	54
SAU supply air unit is designed to provide a comfortable indoor climate with controlled heating and clean, filtered air. SAU is available with AC and EC motors. Airflows up to 1000 m <sup>3</sup> /h (0.28 m <sup>3</sup> /s).	

### ACCESSORIES

<b>HERU® ASSESSORIES</b>	
<b>FILTER</b> .....	74
<b>FEET, NOVIBRA MATS, FLOOR STAND</b> .....	75
<b>CEILING MOUNTING PLATE</b> .....	75
<b>COVER STRIP, FRONT COVER</b> .....	75
<b>OUTSIDE WALL HOOD</b> .....	76
<b>CONTROL KIT</b> .....	77
<b>CONTROL SYSTEM SIEMENS CLIMATIX</b> .....	77
<b>HEATERS</b> .....	78
<b>COOLING COILS</b> .....	78
<b>RELAY PUMP CONTROL</b> .....	78
<b>PRESSURE SENSOR KIT</b> .....	79
<b>DAMPERS</b> .....	79
<b>FLOW METERS</b> .....	79
<b>FILTER MONITORING</b> .....	79
<b>SHUNT</b> .....	79
<b>WATER TRAP</b> .....	79
<b>SAU ACCESSORIES</b>	
<b>FILTER</b> .....	80
<b>FAN CONTROL UNITS</b> .....	80
<b>CONTROL KIT</b> .....	80
<b>REMOTE CONTROL</b> .....	81
<b>ANTENNA</b> .....	81
<b>CONTROL UNIT</b> .....	81
<b>OTHERS ACCESSORIES</b>	
<b>SENSORS</b> .....	82
<b>EXTENSION CABLE, ANTENNA</b> .....	82
<b>SILENCERS</b> .....	83
<b>MOUNTING CLAMP</b> .....	83
<b>BACK DRAUGHT SHUTTERS</b> .....	83
<b>SAFETY GRILLE</b> .....	83
<b>LOUVRE SHUTTER</b> .....	83

# FILTER

Energy efficient air filter classes according to EN ISO 16890.

- ePM1:** Filtration efficiencies 50–65%.  
Particle size up to 1 µm.
- ePM2,5:** Filtration efficiencies 50–65%.  
Particle size up to 2.5 µm.
- ePM10:** Filtration efficiencies 50–65%.  
Particle size up to 10 µm.
- Coarse:** Filtration efficiencies 80%.  
Particles all sizes.

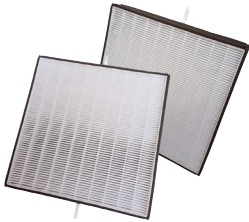

**FILTERKIT HERU® 50/90 LP AND HERU® 70 K**  
These compact filters ISO ePM1 50% are used in the **HERU®LP** and **HERU®K** energy recovery units. The filter kit contains two filters, the same size for supply and exhaust air.

FILTERKIT ISO ePM1 50%	Art.no.
HERU®50/90 LP	6000279
HERU®70 K	6000280



**FILTERKIT HERU® 95-250 T**  
These compact incinerable filters ISO ePM1 50% are used in the **HERU®T** energy recovery units. The filter kit contains two filters.

FILTERKIT ISO ePM1 50%	Art.no.
HERU®95 T	6000275
HERU®100 T	6000276
HERU®160 T	6000277
HERU®200/250 T	6000278

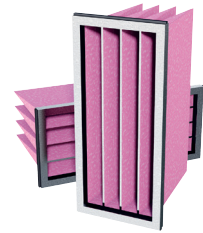

**FILTERKIT HERU® 100-250 S**  
These bag filters ISO ePM1 65% are used in the **HERU®S** energy recovery units. The filter kit contains two filters, the same size for supply and exhaust air.

FILTERKIT ISO ePM1 65%	Art.no.
HERU®100 S	6000211
HERU®130 S	6000214
HERU®180/250 S	6000218



**FILTER HERU® 100-250 S**  
These bag filters ISO 16890 Coarse 80%, are used in the **HERU®S** energy recovery units. They are supplied individually, the same for both supply and exhaust air.

FILTER ISO 16890 Coarse 80%	Art.no.
HERU®100S, 2 pc per unit	1250123
HERU®130S, 2 pc per unit	1250146
HERU®180/250S, 2 pc per unit	1250134

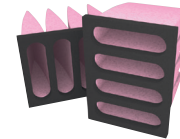

FILTER HERU®400-600T/S



FILTER HERU®800-1200T/S

**FILTER HERU® 400-1200T/S**  
These bag filters, are used in the **HERU®T** and **S** energy recovery units. They are supplied individually.

FILTER ISO ePM1 65%	Art.no.
HERU®400 & 600 T, 4 pc per unit	993030511
HERU®400 & 600 S, 4 pc per unit	993030063
HERU®800 & 1200 T (total 4 pc per unit)	993030513
(2 for supply and 2 for exhaust air)	993030515
HERU®800 & 1200 S, 4 pc per unit	993030513

## FEET

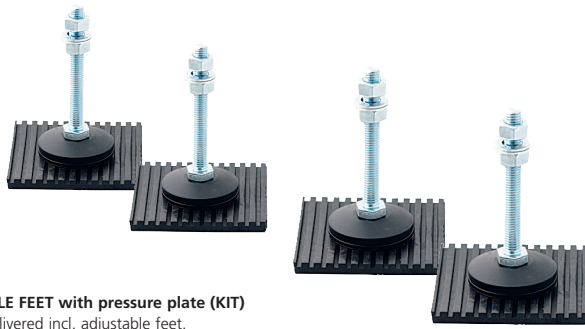

**ADJUSTABLE FEET with pressure plate (KIT)**  
HERU® is delivered incl. adjustable feet.  
Adjustable feet to balance the unit against uneven ground.  
Also used for raising the unit to facilitate cleaning.  
Adjustable from 20 to 100 mm.

Type	Art.no.
HERU®200/250 T (Kit 4 pc)	994060009
HERU®400/600/800/1200 T/S (Kit 8 pc)	994060010

## NOVIBRA MATS



**NOVIBRA MATS (KIT)**  
Double Novibra mat with transversal grooves.  
Thickness 8 mm. Excl. adjustable feet.

Type	Art.no.
HERU®200/250 T (Kit 4 pc)	994060006
HERU®400/600/800/1200 T/S (Kit 8 pc)	994060007

## FLOOR STAND

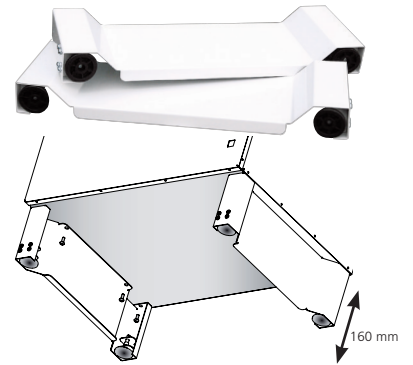

**FLOOR STAND HERU®T**  
Floor stand for HERU®T, with adjustable feet to ensure the unit remains stable even on uneven surfaces.  
Easy to set up.

Type	Art. no.
Floor stand HERU®160 T, white	8010400

## CEILING MOUNTING PLATE

**CEILING MOUNTING PLATE**  
Use the ceiling mounting plate for a smoothly pre-assemble in the ventilation system.  
It is then easy to install HERU®100 T EC on site. Only the wall plug, antenna and duct sensor need to be installed.  
The ceiling mounting plate does not have a cooker hood connection.

Type	Art.no.
Ceiling mounting plate for HERU®100 T EC	8010476

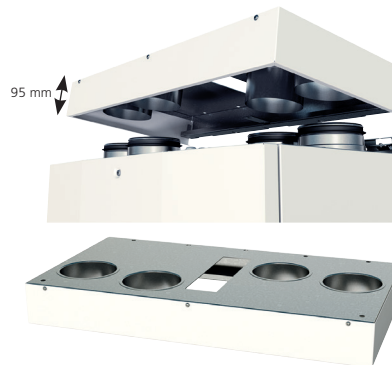
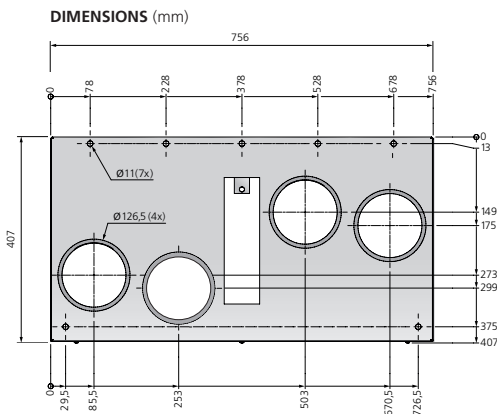

## COVER STRIP

**COVER STRIP**  
A cover strip for HERU® K. Made from stainless steel to fit in with the other interior.

Type	Art.nr.
Cover strip HERU® K	1221200



## FRONT COVER

**FRONT COVER**  
Front cover for HERU®K, plain white in sheet metal, as an option for the kitchen hatch.

Type	Art.no.
Front cover for HERU®70 K	6010542



# OUTSIDE WALL HOOD

## OUTSIDE WALL HOOD

The outside wall hood from Östberg is a fresh air and exhaust air diffuser for wall mounting. The outside wall hood is used to bring fresh air in from below through a wire mesh grille. The exhaust air is transported horizontally out through a wire mesh grille on the front of the outside wall hood. This design prevents short-circuiting of fresh air and exhaust air.

It also effectively prevents the evacuation of water in the fresh air. The outside wall hood is mounted on the outer wall and is reversible for right- and left-hand mounting. The outside wall hood is made of weather-resistant, powder-coated galvanized steel and is available in black or white.



Type	Art.no.
Outside wall hood Ø 160 Black	8200101
Outside wall hood Ø 160 White	8200102
Outside wall hood Ø 200 Black	8200103
Outside wall hood Ø 200 White	8200104

### TECHNICAL DATA

**Weight**    **Ø 160:** 3,6 kg    **Ø 200:** 4,7 kg

### DIMENSIONS (mm)

#### OUTSIDE WALL HOOD Ø 160

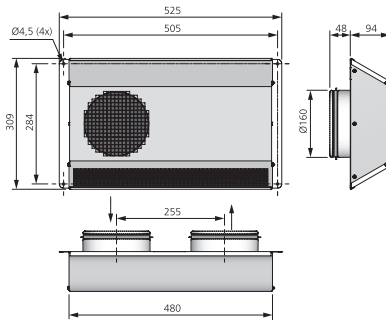

#### OUTSIDE WALL HOOD Ø 200

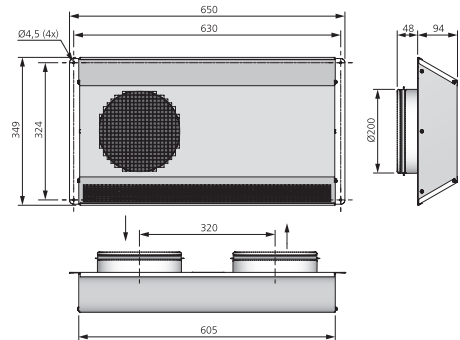

### PRESSURE DROP

#### OUTSIDE WALL HOOD Ø 160

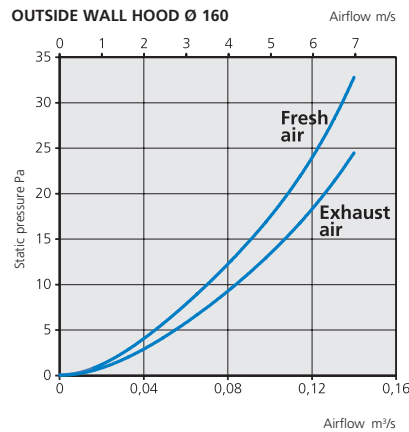

#### OUTSIDE WALL HOOD Ø 200

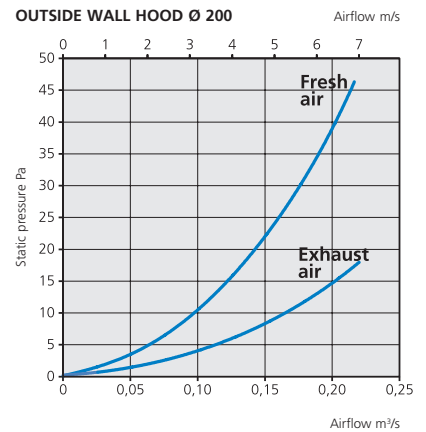



## CONTROL KIT

**CONTROL KIT: Remote Ctrl + Ctrl Board + Antenna**  
HERU® up to size 250 T/S is remote-controlled using the included wireless control unit (remote control), which monitors and controls the ventilation in the building. There are also a number of other needs-based and practical functions.

For easy handling, the remote control should be placed in a central location, such as in the hall. It has a range of up to 50 metres and works through walls and ceilings.

There is a Control Kit that contains a remote control, control board and antenna. These are also available as separate parts.

The control board is hardware for Modbus, but the function is disabled by default. It can be activated with a Modbus-compatible remote control, which is then synchronized with the unit and simplifies activation with the Modbus functions. All HERU® units come prepared for Modbus communication via RS485.

**CONTROL FUNCTIONS**

The wireless control unit is used to set all parameters for the control functions such as:

- Desired fan speed.
- Desired supply, room or extract air temperature.
- Electric heater settings.
- Time for airflow boost.
- Pressure compensation when using a wood-burning stove or open fireplace.
- Installation of weekly clock for periodic fluctuations in fan speeds.
- Summer cooling, airflow boost without heat recovery.

**INFORMATION**

The wireless control unit can provide information on current status (requires additional accessories in some cases) such as:

- Current temperature efficiency.
- Temperature of fresh, extract, exhaust and indoor air after the heat exchanger.
- Temperature in the supply air duct.
- Fan speeds.
- If the rotating heat exchanger is running.
- Heating/cooling demands.
- Carbon dioxide level/relative air humidity (if sensor is connected).
- If pressure compensation is on/off.
- If boost is on/off.
- Day and time

**ALARM**

Examples of alarms shown:

- Filter change.
- Error message for rotating heat exchanger.
- Low air supply temperature.
- Smoke detector triggered.
- Freeze protection for Heater kit, water triggered.

**MODBUS**

We have chosen Modbus communication for HERU® because it is a global standard, easy to implement in its own systems and offers many options for configuration with other systems.

Modbus offers a number of options for communication. These range from a single computer monitoring one unit, to a complete BMS system monitoring an entire building or several buildings at the same time. The MODBUS function requires Modbus remote control (additional accessory)

Type	Art.no.
Control Kit incl. remote control + control board + antenna	4020452
Remote control	4020454
Remote control 3.08 incl. Modbus	4020554
Control board	4020453
Antenna 1.5 m	4020552
Extension cable for antenna 10 m	6010011

**CONTROL SYSTEM: Siemens Climatix**

HERU® from size 400 T/S and onward is available with or without a control system. The unit can be ordered without a control system. For this option, the electricity to the fans and rotor motor is routed to a terminal block in the electrical box, requiring on-site installation by an electrician.

If you choose a unit with a control system, we offer Siemens Climatix for many functions and communication options. The control and regulation system sends prompt alarms if the unit stops and for other unforeseen events. This service-friendly solution enables stops to be rectified quickly, minimizing consequences for the occupants of the premises.

Integrated control equipment in the unit: Modbus communication, efficiency measurement and 1-3 fan speeds are standard.

**CONTROL FUNCTIONS**

The wireless control unit is used to set all parameters for the control functions, such as:

- Temperature regulation. The supply air temperature sensor maintains the supply air temperature through sequential regulation. The supply air setpoint is outside-temperature compensated according to the set curve.
- Extract air control/room control. The extract air temperature sensor maintains the extract air temperature through sequential regulation. The supply air temperature sensor limits the supply air temperature according to minimum and maximum settings. The extract air setpoint is outside-temperature compensated according to a set curve. If the extract air sensor is replaced with or supplemented with a room sensor, room control is achieved.
- Airflow regulation. Fixed fan speed, one to four speeds. The setpoint for one to four speeds is set using the control unit. A timing channel is used to switch between the speeds.
- Pressure regulation. Pressure regulation, supply air fan, extract air fan (VAV control) The pressure in the supply and extract air ducts is kept constant via pressure sensors and speed control of the fans.
- Air quality (CO<sub>2</sub>) control fans. When the CO<sub>2</sub> sensor (room or duct sensor) exceeds the setpoint, the air volume is increased until the setpoint is reached.



- Humidity regulation (Rh) control fans. When the Rh sensor (room or duct sensor) exceeds the setpoint, the air volume is increased until the setpoint is reached.
- Rotating heat exchanger. The heat exchanger power is regulated in sequence with the heating and cooling coil rotation speed. The rotation speed and the recover rate are controlled by the heat exchanger's internal control unit.
- Efficiency measurement HEAT EXCHANGER. Temperature efficiency rate is measured over the heat exchanger when the control signal is 100%.
- Electric Heater kit, water. Electrical heater power is regulated in sequence with the heat exchanger and cooling coil. Requisite control equipment for power regulation is integrated in the air heater. The electrical heater is cooled during regular stops of the unit.
- Heater kit, water. Heater kit, water power is regulated in sequence with the heat exchanger and cooling coil. The coil is supplied with a Freeze protection sensor that forces open the valve if it detects a risk of freezing. The unit then stops and keeps the coil warm during standstill.
- Cooling coil. Cooling coil power is regulated in sequence with heat recovery and Heater kit, water.
- Night cooling. The unit starts up at night to cool the premises with fresh air.

## CONTROL SYSTEM SIEMENS CLIMATIX

- Cool recovery via rotating HEAT EXCHANGER. If cooling is needed and the fresh air temperature exceeds the extract air's set temperature, the recovery system will start up to cool the fresh air.
- Control using annual clock. The weekly schedule is a seven-day schedule for start/stop and for two- to four-speed operation with the option to set the unit for different weekend schedules.

**OPERATING INFORMATION**

Using the control unit, the following operating information can be easily read:

- The actual temperature of supply air, extract air and fresh air.
- Operating status.
- Fan status.
- Current setpoints.
- Power signals.

**ALARM AND OPERATION STATUS**

Displayed prominently on the control unit.

The following events trigger status reports:

- Filter monitor. Filter monitors Supply air fan/Extract air fan. When pressure exceeds the set value for any filter monitor, an alarm will be triggered.
- Deviation from the supply air temperature's setpoint.
- Alarm from rotating heat recovery system, electrical heater, Freeze protection sensor, supply air/extract air fan, sensor error, filter monitors, external smoke/fire detectors, etc.
- The main alarm is connected to the terminal in the unit to enable further transmission.

Type	Art.no.
CLIMATIX-600 OPC licence	994020785
CLIMATIX-600 BACnet IP, Installed	999051021
CLIMATIX-600 LON, Installed	999051022
CLIMATIX-600 GSM modem, Installed	999051024
CLIMATIX-HMI-DM, ExternDisplay IP31	994020653

# HEATERS

**HEATER KIT, WATER FOR HERU® ≤ 250 T/S**  
 2 or 5 kW, incl. 2- or 3-way valve, motor and Freeze protection sensor. Duct reduction also included as needed.

Type	Art.no.
<b>Heater Kit Water incl. 2-way valve</b>	
2,0 kW HERU®100 S	8010305
2,0 kW HERU®100 T	8010306
5,0 kW HERU®130 S	8010035
5,0 kW HERU®180/250 S, 200/250 T	8010031
5,0 kW HERU®160 T	8010064
<b>Heater Kit Water incl. 3-way valve</b>	
2,0 kW HERU®100 S	8010403
2,0 kW HERU®100 T	8010404
5,0 kW HERU®130 S	8010036
5,0 kW HERU®180/250 S, 200/250 T	8010032
5,0 kW HERU®160 T	8010065

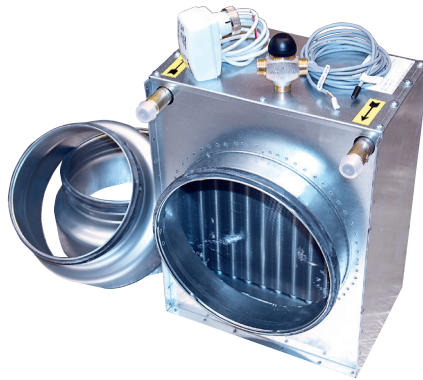

**TECHNICAL DATA**

<b>Power:</b>	<b>kW</b>
<b>Air:</b>	
<b>Airflow:</b>	0,20 m³/s
<b>Speed:</b>	0,20 m³/s
<b>Temp. in:</b>	10 °C
<b>Temp. out:</b>	30,50 °C
<b>Hot water:</b>	
<b>Speed:</b>	0,10 l/s
<b>Speed:</b>	0,86 m/s
<b>Temp. supply pipe:</b>	60 °C
<b>Temp. return:</b>	40 °C
<b>Pressure drop:</b>	2,10 15,00 k Pa

**DIMENSIONS (mm)**

**2 kW**

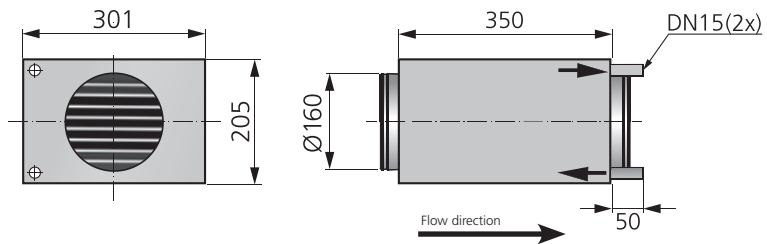

**5 kW**

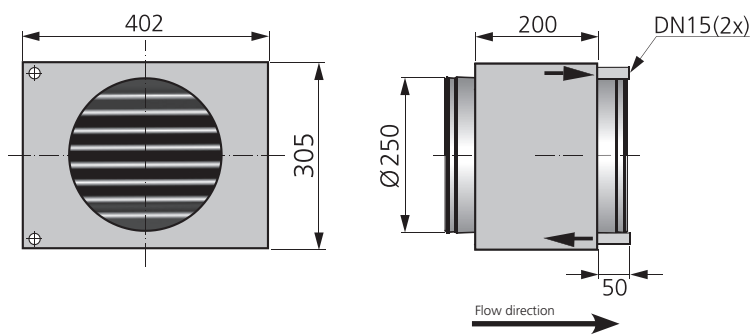

**BATTERY PRESSURE DROP**

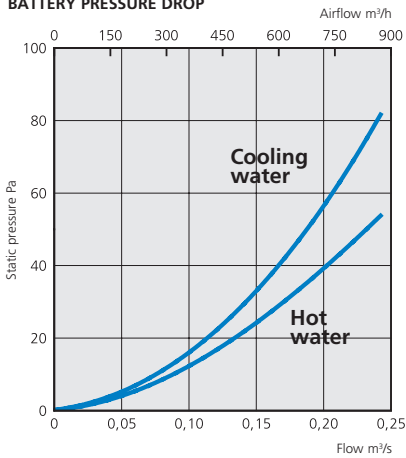

# COOLING COILS

**COOLING COIL KIT FOR HERU® ≤ 250 T/S**  
 2,5 kW, incl 2- or 3-way valve and actuator. Reducing sockets also included when needed.

Type	Art.no.
<b>Cooling coil Kit incl. 2-way valve</b>	
2,5 kW HERU®160 T	8010066
2,5 kW HERU®130 S	8010037
2,5 kW HERU®180/250S, 200/250T	8010033
<b>Cooling coil Kit incl. 3-way valve</b>	
2,5 kW HERU®160 T	8010067
2,5 kW HERU®130 S	8010038
2,5 kW HERU®180/250S, 200/250T	8010034

**COOLING COIL FOR HERU® ≥ 400 T/S**

Cooling coil for placement in duct, with stainless steel drip plate. Circular or rectangular connection. Please contact Östberg for more information of our wide range.



# RELAY PUMP CONTROL

**RELAY PUMP CONTROL**

Relay for pump control of heating/cooling battery.

Type	Art.no.
Relay pump control	6000195

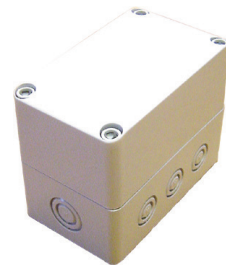



## PRESSURE SENSOR KIT

### DIFFERENTIAL PRESSURE SENSORS FOR HERU® ≥ 400 T/S

**QBM 68**, pressure and flow for air and non-aggressive gases.

**QBM 69** for flow and non-aggressive gases.

Type	Art.no.
Differential pressure sensor QBM68 1200	994020910
Differential pressure sensor QBM68 2500	994020911
Differential pressure sensor QBM68 2525	994020913
Differential Pressure sensor QBM69 2525	
+2xTemp	994020915



### PRESSURE SENSOR KIT FOR HERU® ≤ 250 T/S

Consists of 2 DTL pressure sensors with hose.

DTL is a transmitter for differential pressure measurement of air and non-corrosive gases in air handling units etc.

For constant pressure control.

High level of accuracy and stability.

Quick and easy mounting.

Type	Art.no.
Pressure sensor Kit	6010067
Pressure sensor DTL310 with hose	4020032

## DAMPERS

### DAMPER MOTOR WITH SPRING RETURN

Overload protection and stop detector for efficient energy use. Used for shutting off and throttling dampers.

Sturdy, made entirely of metal and maintenance-free. Fits all mounting positions. Change the direction of rotation by simply turning the device.

Type	Art.no.
Damper motor 230V	1220448
Damper motor 7Nm 24VAC	993061001
Damper motor 3-pos. 10Nm 24VAC	993061004

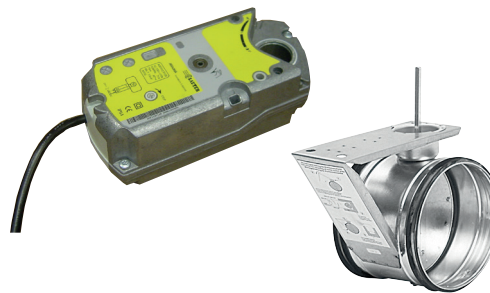

### DAMPERS

Circular and rectangular dampers with motorrack for HERU® from size 400 T/S.

Type	Art.no.
Damper Ø D315 with motor bracket	993060001
Damper Ø D400 with motor bracket	993060002
Damper Rect. 800x400 gejd/gejd	993060175
Damper Rect. 1000x300 gejd/gejd	993060013
Damper Rect. 1200x600 gejd/gejd	993060098

## FLOW METERS

### FOR HERU® ≥ 400 T/S

Analog or digital for measuring current flow.

Socket for flow meter is included and placed on top of the unit.

Type	Art.no.
Flow meter Digital univ. K-fac	994020619
Flow meter Analog 0-1300 Pa	994090001
U-pipe senso meters	994090001

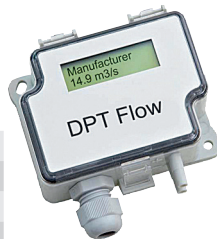

## FILTER MONITORING

### FOR HERU® ≥ 400 T/S.

Accessory that help keeps control of the filter conditions in the unit.

Measuring the differential pressure over the filter for alarm, or gives information about the pressure level.

Type	Art.no.
Filter guard 300 Pa, 5 m cable	995010011
Filter guard w. Display, 5 m cable	995010014
U-pipe filter MMU, +/-500Pa	994090005

### VALVE ACTUATOR

Valve actuator for HERU® ≥ 400 T/S.

To control 2-way and 3-way valves with a lift height of 5.5 mm.

Fits both cooling and heating shunts.



Type	Art.no.
Valve actuator	994030060

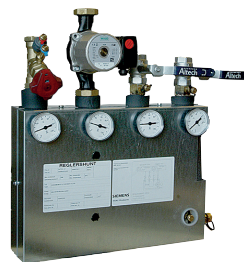

### FOR HERU® ≥ 400 T/S

A traditionally welded pipe connection with a primary and secondary side, control valve, freeze protection antirainback valve, shutdown valves, adjustment valves and secondary pump – all in one unit. Features heat insulation with mineral wool or cold insulation with Armaflex.

## SHUNT

Type	Art.no.
Water trap	994070010



### Water trap

Accessory for cooling coil. Plastic water trap with float valve.

Underpressure maximum 800 Pa.

Overpressure maximum 500 Pa.

## WATER TRAP

## FILTER

Energy efficient air filter classes according to EN ISO 16890.

- ePM1:** Filtration efficiencies 50–65%  
Particle size up to 1 µm
- ePM2,5:** Filtration efficiencies 50–65%  
Particle size up to 2.5 µm
- ePM10:** Filtration efficiencies 50–65%  
Particle size up to 10 µm
- Coarse:** Filtration efficiencies 65-80%  
Particles all sizes



### FILTER SAU AC

These filters are used in the SAU AC supply air unit. There are three different filter classes to choose from.

Type	Art.no.
Filter ISO 16890 Coarse 65% SAU 125 AC	1250117
Filter ISO 16890 Coarse 80% SAU 125 AC	1250118
Filter ISO ePM1 65% SAU 125 AC	1250119
Filter ISO 16890 Coarse 65% SAU 200 AC	1250120
Filter ISO 16890 Coarse 80% SAU 200 AC	1250121
Filter ISO ePM1 65% SAU 200 AC	1250122
Filter ISO 16890 Coarse 65% SAU 250 AC	1250135
Filter ISO 16890 Coarse 80% SAU 250 AC	1250136
Filter ISO ePM1 65% SAU 250 AC	1250137



### FILTER SAU EC

These filters are used in the SAU EC supply air unit. Compact incinerable filters. The unit is delivered with filter ISO ePM1 50% as standard. Filter ISO ePM2.5 60% is available as an accessory.

Type	Art.no.
Filter ISO ePM2.5 60% SAU 125 EC	1250237
Filter ISO ePM1 50% SAU 125 EC	1250239
Filter ISO ePM2.5 60% SAU 200 EC	1250238
Filter ISO ePM1 50% SAU 200 EC	1250240
Filter ISO ePM2.5 60% SAU 250 EC	1250241
Filter ISO ePM1 50% SAU 250 EC	1250242

## FAN CONTROL UNITS

### FAN CONTROL UNITS FOR SAU AC

Type	Art.no.
Single-phase fan control unit for SAU 125 and 200	6000056
3-phase fan control unit for SAU 200	6000057



## CONTROL KIT

### CONTROL KIT FOR SAU 250 E AC

Complete kit that includes 2- or 3-way valve, thermal actuator, duct sensor with attachment to sensor, room temperature regulator and transformer.

Type	Art.no.
Control Kit 2-way valve	6000149
Control Kit 3-way valve	6000124



## REMOTE CONTROL



### REMOTE CONTROL FOR SAU EC.

The remote control monitors and controls the ventilation in the building. There are also a number of other needs-based and practical functions.

The remote control unit is used to set all parameters for the control functions.

The remote control unit can provide information on current status (requires additional accessories in some cases).

Triggered alarms are displayed prominently.

For easy handling, the remote control should be placed in a central location, such as in the hall. It has a range of up to 50 meters and works through walls and ceilings.

If choosing the remote control, the antenna (Art.no. 4020552) is needed.

Type	Art.no.
Remote control	4020651

## ANTENNA



### ANTENNA

Antenna with 1.5 m cord.

The antenna should be mounted outside the unit.

The antenna should not be mounted against any metal area or metal items as this will shield the signal.

The antenna should be mounted as central as possible.

This to achieve the best signal all over the house.

If needed an extension cord is available as an accessory.

Type	Art.no.
Antenna	4020552

### CONNECTION CORD

Connection cord for the control unit, 10 m.

Type	Art.no.
Connection cord, 10 m	4020653



## CONTROL UNIT

### CONTROL UNIT FOR SAU EC.

External control unit for operating and to preset the required temperature as well as monitor the unit's status.

Different modes such as Away and Normal mode can also be scheduled.

A Led light simply shows the status of the unit.

The control unit is designed to be placed recessed on the wall.

Connection cord is needed when ordering the control unit.

The SAU EC is delivered included the external control unit and connection cord as standard.

Type	Art.no.
Control unit	4020652

# OTHERS ACCESSORIES

## SENSORS



### CARBON DIOXIDE SENSOR CO2

Sensor for carbon dioxide, CO<sub>2</sub>, for installation in room. It digitally measures both CO<sub>2</sub> concentration and temperature in the ambient air. The data is transmitted to a BMS system or controller.

According to building regulations, the fresh air flow should be at least 7 litres/sec and person in rooms occupied by humans for any length of time.

#### DIMENSIONS (mm)

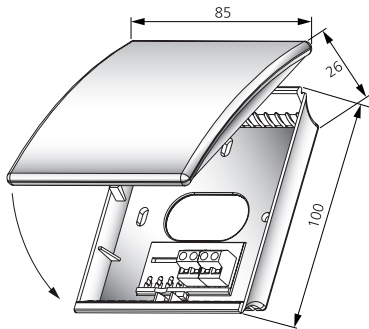

#### WIRING DIAGRAM

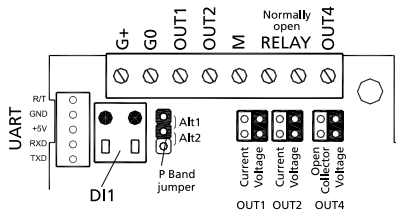

### HUMIDITY SENSOR RH

Humidity sensor RH, relative humidity, for installation in room.

Microprocessor controlled electronics guarantee optimal accuracy. Humidity output is 4-20 mA or 0-10 V as standard.

The sensor is easy to install.

#### DIMENSIONS (mm)

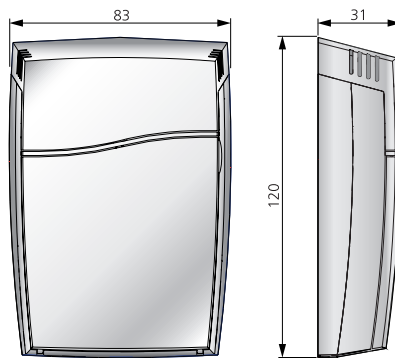

#### WIRING DIAGRAM

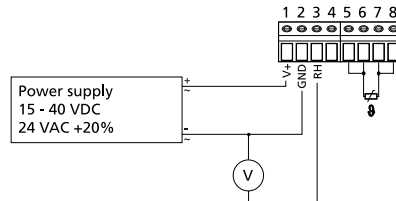

### ROOM TEMPERATURE SENSOR

Temperature sensor for placement in the room.

With screw terminal block attachment for optional signal cable.

#### DIMENSIONS (mm)

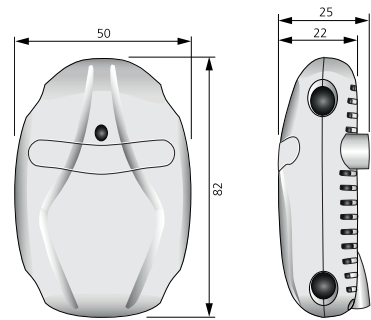

Type	Art.no.
Room sensor CO2	4020302
Room sensor CO <sub>2</sub> , HERU <sup>®</sup> ≥ 400 T/S	994020623
Room sensor RH	4020301
Room sensor RH, HERU <sup>®</sup> ≥ 400 T/S	994020621
Room sensor Temp	4020310

## DUCT SENSORS

### DUCT SENSORS

For measuring air temperature in ventilation ducts.

Type	Art.no.
Duct sensor 1.5 m cable	4020286
Duct sensor CO <sub>2</sub> , HERU <sup>®</sup> ≥ 400 T/S	994020622
Duct sensor CO <sub>2</sub> 200 ppm, HERU <sup>®</sup> ≥ 400 T/S	995010012
Duct sensor RH, HERU <sup>®</sup> ≥ 400 T/S	994020620
Duct sensor outdoor temp, HERU <sup>®</sup> ≥ 400 T/S	994040507
Duct sensor Pressure, HERU <sup>®</sup> ≥ 400 T/S	995010046



## FREEZE PROTECTION SENSOR

### FREEZE PROTECTION SENSOR

For placement on the return pipe of the heating coil.

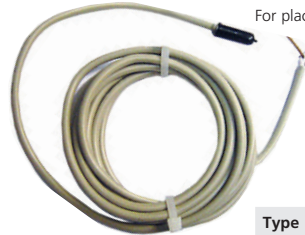

Type	Art.no.
Freeze protection sensor	4020309

## EXTENSION CABLE, ANTENNA

### EXTENSION CABLE, ANTENNA 10 M.

Type	Art.no.
Extension cable for antenna, 10 m.	6010011



## SILENCERS

**SILENCERS**

LDC is a circular silencer with lengths 600 mm or 900 mm in each size.

The silencer consists of a perforated duct inside, end caps and outer casing, all of galvanized steel.

The intervening space is filled with 50 mm stone wool insulation.

Type	Art.no.
LDC 125x600 mm	9530004
LDC 125x900 mm	9530005
LDC 160x600 mm	9530008
LDC 160x900 mm	9530009
LDC 200x600 mm	9530010
LDC 200x900 mm	9530011
LDC 250x600 mm	9530012
LDC 250x900 mm	9530013



Ø315 600 mm	993100003
Ø315 900 mm	993100004
Ø400 600 mm	993100005
Ø400 900 mm	993100006

**SILENCERS LDR**

LDR is a range of rectangular silencers from the size 300x150 to 1000x500 mm.

LDR is made from galvanized steel sheet.

The baffles consist of environmentally friendly sound insulation with a durable surface layer.

Type	Art.no.
LDR 300x150	9530019
LDR 400x200	9530020
LDR 500x250	9530021
LDR 500x300	9530022
LDR 600x300	9530023
LDR 600x350	9530024
LDR 700x400	9530025
LDR 800x500	9530026
LDR 1000x500	9530027

## MOUNTING CLAMP

Type	Art.no.
Mounting clamp MK 125	9560003
Mounting clamp MK 200	9560006
Mounting clamp MK 250	9560007

**MOUNTING CLAMP MK**

The fan can be connected to duct with mounting clamp MK.

The mounting clamp is made of galvanized steel sheet with a rubber seal to fit tightly and absorb vibrations.

The mounting clamp makes the fan easy to remove for cleaning and maintenance.

## BACK DRAUGHT SHUTTERS

Type	Art.no.
Back draught shutter RSK 125	9520030
Back draught shutter RSK 200	9520033
Back draught shutter RSK 250	9520034

**BACK DRAUGHT SHUTTERS, RSK**

RSK is used for circular ducts and is made from galvanized steel with spring-loaded lamina from aluminium.

## SAFETY GRILLE

**SAFETY GRILLE BSR**

BSR is a safety grille with straight lugs for mounting on flat surfaces.

Should also be used on fans that are not connected to ducts to obtain insulation class IP 44.

It is manufactured from galvanized steel mesh.

Type	Art.no.
Safety grille BSR 125	9520061
Safety grille BSR 200	9520007
Safety grille BSR 250	9520010

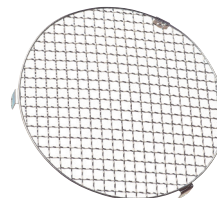
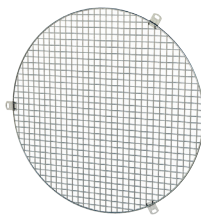
**SAFETY GRILLE BSV**

BSV is a safety grille with angled lugs for mounting on ducts.

Should also be used on fans that are not connected to ducts to obtain insulation class IP 44.

BSV is manufactured from galvanized steel mesh.

Type	Art.no.
Safety grille BSV 125	9520003
Safety grille BSV 200	9520008
Safety grille BSV 250	9520011

## LOUVRE SHUTTERS

Type	Art.no.
Louvre shutter VK 125	9520020
Louvre shutter VK 200	9520022
Louvre shutter VK 250	9520023

**LOUVRE SHUTTERS VK**

VK self-closing louvre shutters are manufactured from UV-resistant material.

They are characterized, among other things, by a very low airflow resistance.

For example 10 Pa at 4 m/s air speed, 30 Pa at 6.5 m/s and 50 Pa at 8.5 m/s.





energy  
efficient  
ventilation

**ÖSTBERG** 

**H. ÖSTBERG AB**

Box 54, SE-774 22 Avesta, Sweden  
Phone: +46 226 860 00  
E-mail: [info@ostberg.com](mailto:info@ostberg.com)  
[www.ostberg.com](http://www.ostberg.com)